The background of the slide features a repeating pattern of a stylized motorcycle icon in a light blue color. The icon is oriented diagonally, facing towards the top right. The pattern is dense and covers the entire area of the slide.

Tablas de valores  
de referencia  
para el ensayo  
con el vehículo parado



## INDICE

Ensayo de referencia con el vehículo parado .....	3
Relación de empresas fabricantes/comercializadoras de instrumentos de medición .....	7
Tablas de valores de referencia de vehículos homologados en España .....	9
APRILIA .....	9
BENELLI .....	11
BETA .....	11
BETA-TRUEBA .....	12
BMW .....	12
BULTACO .....	14
CAGIVA .....	15
DERBI .....	16
GAS GAS .....	18
GILERA .....	19
HONDA .....	22
HUSABERG .....	28
HUSQVARNA .....	28
HYOSUNG .....	29
ITALIET .....	29
KAWASAKI .....	29
KYMCO .....	33
KTM .....	34
MALAGUTI .....	34
MBK .....	35
MONTESA .....	35
MOTO GUZZI .....	36
MOTOR HISPANIA .....	36
MuZ .....	37
MV AGUSTA .....	37
PGO .....	37
PEUGEOT .....	37
PIAGGIO .....	38
RIEJU .....	42
SHERCO .....	42
SUZUKI .....	43
TRIUMPH .....	47
YAMAHA .....	49

## ENSAYO DE REFERENCIA CON EL VEHÍCULO PARADO

A continuación resumimos los métodos de ensayo que se aplican, en cada caso, según el Reglamento o Directiva con que fue homologado el vehículo.

Procedimiento de ensayo

MOTOCICLETAS Y CICLOMOTORES - Directivas CEE 78/1015, 87/56, 89/235 y 97/24/CE cap. 9.

El micrófono se colocará como se muestra en la figura.

## ENSAYO CON EL VEHICULO PARADO

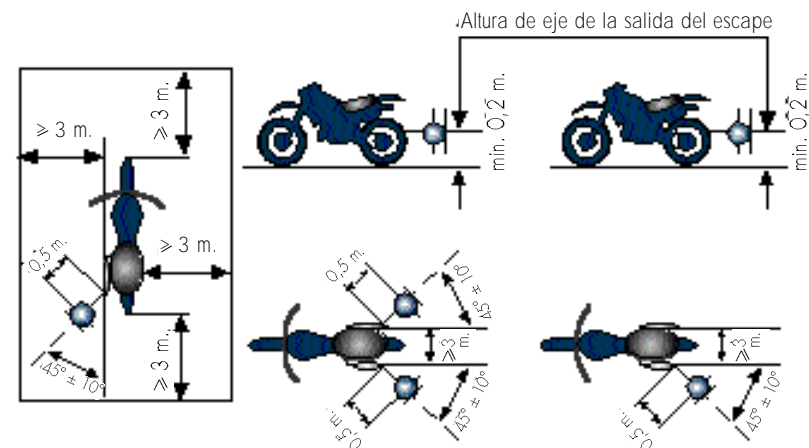

A efectos prácticos, se suele construir una escuadra como ayuda al posicionamiento del micrófono. En anexo al manual titulado "El Ruido en Ciclomotores y Motocicletas", incluimos una plantilla para realizarla, aunque se puede usar una simple escuadra de papelería que mida en su lado diagonal 50 cm.

Características del área de ensayo

El área de ensayo no deberá estar sujeta a perturbaciones acústicas importantes: muros, plantas... La superficie deberá ser plana y estar pavimentada



con hormigón, asfalto o cualquier otro revestimiento duro. Tendrá la forma de un rectángulo cuyos lados estarán, como mínimo, a 3 m. de los puntos extremos de la motocicleta, excluido el manillar.

No deberá encontrarse en su interior ningún obstáculo importante ni persona distinta del observador y el conductor. Si existe bordillo, la motocicleta se colocará dentro de dicho rectángulo, de forma que el micrófono de medición diste como mínimo un metro.

#### Nivel sonoro ambiente

Las lecturas del instrumento de medida causadas por el ruido ambiente y el viento deberán ser, como mínimo, inferiores en 10 dB al nivel sonoro que haya de medirse.

(El micrófono podrá estar dotado de pantalla de protección contra el viento, siempre que se tenga en cuenta su influencia sobre la sensibilidad del micrófono).

#### Colocación del micrófono

Se situará a la altura de la salida del escape y en ningún caso a menos de 0'2 m. por encima de la superficie de la pista.

La membrana del micrófono se orientará hacia la boca de salida de los gases a una distancia de 0'5 m. de dicha boca.

El eje de sensibilidad máxima del micrófono deberá estar paralelo a la superficie de la pista y formar un ángulo de  $45^\circ \pm 10^\circ$  con el plano vertical en el que se inscribe la dirección de salida de los gases de escape.

Si la motocicleta tiene varias salidas del escape y estas distan entre sí hasta 0'3 m., se orientará el micrófono hacia la que esté situada más hacia el exterior o hacia la más alta.

Si la motocicleta tiene varias salidas del escape y estas distan entre sí más de 0'3 m., se realizarán medidas distintas en cada salida y se tendrá en cuenta el valor más elevado.



#### Régimen del motor

El régimen del motor se estabilizará después de acelerar suavemente a:

$S/2$  si  $S > 5.000$  r.p.m.

$3/4 S$  si  $S < 5.000$  r.p.m.

siendo S el régimen al que se produce la potencia máxima.

La motocicleta se probará, una vez que haya alcanzado su temperatura de funcionamiento normal, con la caja de cambios en punto muerto. Si es automática y esto no es posible, se colocará en un apoyo para que la rueda gire libremente, por ejemplo sobre su caballete.

En las tablas anexas figuran los valores correspondientes al nivel sonoro de referencia y régimen del motor de los modelos más representativos homologados en España, por lo que basta con localizar el vehículo a ensayar en la tabla para conocer los que no se deben superar.

#### Desarrollo del ensayo

En cuanto se alcance el régimen estabilizado definido antes, se llevará el acelerador rápidamente a la posición de ralentí. Se medirá el nivel sonoro durante el régimen estabilizado y la desaceleración, considerándose el mayor valor indicado por el sonómetro.

#### Número de medidas

Se tomarán tres medidas como mínimo en cada uno de los puntos identificados para la colocación del micrófono.

La diferencia entre ellas no deberá ser superior a 2 dB(A). Si no es así, se deberá realizar la prueba de nuevo. Se considerará el valor más alto obtenido en las tres mediciones. (En ciclomotores se considerará la media de las tres mediciones).

#### CICLOMOTORES - Decreto 1439/72.

Esta prueba de referencia es distinta a la anterior, pese a ser también a vehículo parado.

El micrófono se colocará a 7 m. de distancia del vehículo y a 1'2 m. de altura sobre el nivel del suelo.



El régimen se estabilizará a  $3/4 S$ , siendo  $S$  el régimen al que se produce la potencia máxima.

El área de ensayo deberá estar constituida por un espacio abierto de 50 metros de radio cuya parte central, de 20 metros de radio como mínimo, deberá ser horizontal, pavimentada con hormigón, asfalto o material similar.

Estas exigencias y la distancia (7m) al vehículo a controlar hacen muy difícil, sino imposible, la aplicación de estas medidas al control de vehículos en la calle.

### ENSAYO CON EL VEHICULO PARADO

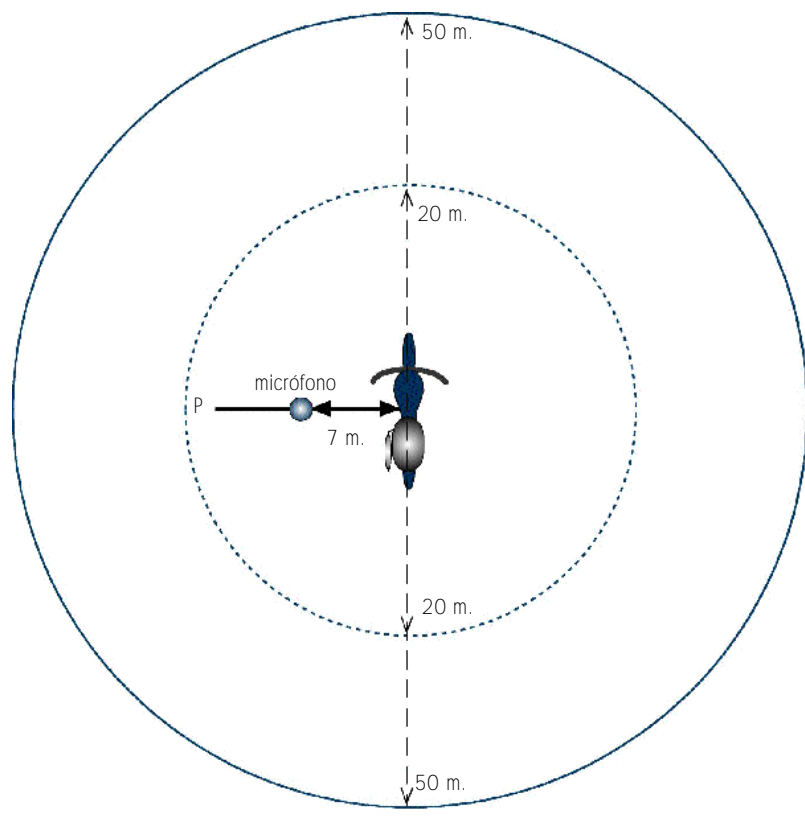

Recomendamos por ello la lectura del apéndice titulado: "Consideraciones sobre la realización práctica de los ensayos con vehículo detenido según Reglamento Nacional para ciclomotores", en anexo al manual titulado "El Ruido en Ciclomotores y Motocicletas".

### RELACION DE EMPRESAS FABRICANTES/ COMERCIALIZADORAS DE INSTRUMENTOS DE MEDICION

#### SONÓMETROS:

- ◆ ALAVA INGENIEROS S.A.  
c) Estébanez Calderón nº 5 - 4ª planta  
28020 MADRID  
Tfno.: 91.567.97.00; Fax: 91.570.26.61

Marca	Modelo
O1 Db	Symphonie
RION	NL-15
RION	NL-18
RION	NA-27
NORSONIC	N-117

- ◆ SPECTRIS ESPAÑA S.A.(BRÜEL & KJÆR)  
c) Teide nº 5  
28700 SAN SEBASTIÁN DE LOS REYES (MADRID)  
Tfno.: 91.659.08.20; Fax: 91.659.08.24

Marca	Modelo
BRÜEL & KJÆR	2238 Mediator
BRÜEL & KJÆR	2260 A, B, F

- ◆ ELETTRORAVA IBERICA SERVICIOS S.L.  
c) Lisboa, Nave 4 - Pol. Ind. Cova Solera  
08191 RUBI (BARCELONA)  
Tfno.: 93.588.76.26; Fax: 93.588.40.89



Marca	Modelo
CIRRUS	CR: 303 B
CIRRUS	CR: 272
CIRRUS	CR: 251 B

- ◆ DICESVA S.L.  
c) Villar nº 4  
08041 BARCELONA  
Tfno.: 93.433.52.40; Fax: 93.347.93.10

Marca	Modelo
CESVA	SC-20e
CESVA	SC-15c
CESVA	SC-3
CESVA	SC-2c

#### TACÓMETROS:

- ◆ INSTRUMENTACIÓN Y AUTOMATIZACIÓN S.A.  
(IROT INGENIEROS)  
Delegación Madrid: c) Balandro nº 40 - Bajo  
28042 MADRID  
Tfno.: 91.742.68.56; Fax: 91.320.49.96  
Central: Edificio Elkartegui - Carretera Bilbao-Balmaseda Km. 9  
48810 ALONSOTEGUI (VIZCAYA)  
Tfno.: 94.498.20.10; Fax: 94.498.21.32

Marca	Modelo
ONOSOKKI	SE 1400

- ◆ OPPAMA  
Se puede adquirir en los concesionarios de marca YAMAHA bajo la referencia: 907938000900

Marca	Modelo
OPPAMA	PET-1000



## TABLAS DE VALORES DE REFERENCIA DE VEHICULOS HOMOLOGADOS EN ESPAÑA

### MARCA: APRILIA

#### Ciclomotores:

Denominación Comercial	Contraseña de Homologación	Tipo	Variante	NIVEL SONORO		
				dB (A)	r.p.m.	Distancia
AMICO 50	CI-0106	FC		65	3.400	7 m.
SR 50	CI-1002	LB		60	3.287	7 m.
RALLY 50	CI-1027	MD00		90	5.062	50 cm.
SCARABEO 50	CI-1028	LE081		90	4.687	50 cm.
RS 50	CI-1044	MM00		74	3.187	50 cm.
GULLIVER 50	CI-1053	LH00		77	4.875	50 cm.
GULLIVER 50 AGUA	CI-1053	LH00	LH07	80	4.687	50 cm.
CLASSIC 50	CI-1054	LP00		81	3.187	50 cm.
SR 50 AGUA	CI-1056	LC	00	84	4.900	50 cm.
RX 50	CI-1058	MU00		76	3.375	50 cm.
RX 50	CI-1058	MU00	02	81	3.000	50 cm.
RALLY 50 AGUA	CI-1071	ND	E0 y E1	85	4.875	50 cm.
SR 50 AGUA	CI-1083	MZ	02 y 03	80	4.500	50 cm.
SR 50 AGUA	CI-1083	MZ	C2 y C3	78	4.500	50 cm.
SR 50 AGUA	CI-1083	MZ	G0 y G1	82	5.062	50 cm.
AR 50 AIRE	CI-1084	LY	02 y 03	82	4.500	50 cm.
AMICO	CI-1095	MK	A1	78	4.500	50 cm.
SONIC (aire)	CI-1111	PB	A0	84	4.500	50 cm.
SONIC (agua)	CI-1111	PB	A1	80	4.500	50 cm.
SCARABEO 50	CI-1112	PF	A0 y A1	80	4.875	50 cm.
AREA 51	CI-1121	MY	A0	85	4.875	50 cm.
RS 50 ('99)	CI-1139	PG	A0	75	3.900	50 cm.
HABANA 50	CI-1148	PK	A0	84	4.687	50 cm.
SR50	e3*92/61* 0012	RL	00 y 01	79	3.250	50 cm.
SR50	e3*92/61* 0012	RL	A0 y A1	82	3.375	50 cm.
SR50	e3*92/61* 0012	RL	B0 y B1	82	3.625	50 cm.

#### Motocicletas:

Denominación Comercial	Contraseña de Homologación	Tipo	Variante	NIVEL SONORO		
				dB (A)	r.p.m.	Distancia
AF1 125 REPLICA	A-0335	AC/1		91	5.000	50 cm.
TUAREG 125	A-0336	DF/1	2DF/2,3,4	90	6.900	50 cm.
AF1 125 REPLICA	A-0367	EH		93	5.000	50 cm.
RED ROSE 125	A-0368	BC		93	5.000	50 cm.

**MARCA: APRILIA****Motocicletas:**

Denominación Comercial	Contraseña de Homologación	Tipo	Variante	NIVEL SONORO		
				dB (A)	r.p.m.	Distancia
RED ROSE 125	A-0368	BC	FA	94	5.000	50 cm.
TUAREG 125 WIND	A-0369	EE		93	6.900	50 cm.
PEGASO 125	A-0402	ET		92	5.000	50 cm.
TUAREG RALLY 125	A-0402	ET	FI	98	5.000	50 cm.
AFI 125	A-0416	FM		94	5.250	50 cm.
EUROPA FUTURA	A-0416	FM	FV, FM	94	5.250	50 cm.
PEGASO 650	A-0546	GA		89	3.125	50 cm.
PEGASO 650	A-0546	GA	MX00	88	3.000	50 cm.
RS 125	A-0547	GS		91	5.500	50 cm.
RS 125 SP	A-0547	GS	SP	91	5.250	50 cm.
RS 125	A-0547	GS	95	91	5.250	50 cm.
CLASSIC 75	A-0575	LK		88	3.750	50 cm.
SCARABEO 65	A-0577	LZ		85	4.000	50 cm.
CLIMBER 280	A-1007	HE		90	4.000	50 cm.
RS 250	A-1019	LD00		90	5.500	50 cm.
RS 250 - 25 kW	A-1019	LD00	25 k	90	4.250	50 cm.
RS 250 (98)	A-1019	LD00	A0	89	5.500	50 cm.
RS 250 (98) - 25 kW	A-1019	LD00	A2	89	3.875	50 cm.
MOTO 6.5	A-1027	MH		90	3.125	50 cm.
LEONARDO 125	A-1037	MB00		92	4.400	50 cm.
PEGASO 650 (97)	A-1072	ML	Std	96	3.125	50 cm.
PEGASO 650(97)-25 kW	A-1072	ML	25	89	2.750	50 cm.
RS 125 - 11 kW	A-1075	MP	A0	84	3.600	50 cm.
RS 125	A-1075	MP	FP	95	5.000	50 cm.
RS 125	A-1075	MP	01	94	5.250	50 cm.
RS 125 (99)	A-1075	MP	B0	94	5.625	50 cm.
RS 125 (99)-11 kW	A-1075	MP	B1	84	3.875	50 cm.
CLASSIC 125	A-1084	MF	04	83	3.550	50 cm.
LEONARDO 150	A-1094	MB	A0	84	4.250	50 cm.
LEONARDO 150 (99)	A-1094	MB	A2	85	4.250	50 cm.
RSV Mille	A-1110	ME	00	96	4.625	50 cm.
RSV Mille SP	A-1110	ME	D0	92	4.625	50 cm.
ETX 125	A-1118	PH	A0	84	3.750	50 cm.
LEONARDO 250	A-1197	PD	00	87	3.550	50 cm.
SCARABEO 125	A-1209	PC	A0	91	4.500	50 cm.
SCARABEO 150	A-1209	PC	00	91	4.250	50 cm.
HABANA 125	A-1231	PM	00 y 01	85	3.750	50 cm.
FALCO 1000	e11*92/61* 00003	PA	00	94	4.625	50 cm.
RSV Mille (2001)	e11*92/61*00027	RP	0	94	4.625	50 cm.

**MARCA: APRILIA****Motocicletas:**

Denominación Comercial	Contraseña de Homologación	Tipo	Variante	NIVEL SONORO		
				dB (A)	r.p.m.	Distancia
RSV Mille R (2001)	e11*92/61*00027	RP	A	94	4.625	50 cm.
ETV 1000 Capo Nord	e11*92/61*00031	PS	0	92	4.125	50 cm.
PEGASO 650 i.e.	e11*92/61*00032	RW	0	85	3.250	50 cm.
PEGASO 650 i.e. (25kW)	e11*92/61*00032	RW	A	83	2.875	50 cm.
SCARABEO 200	e11*92/61*00034	SD	0	86	4.500	50 cm.
SCARABEO 100	e3*92/61*0005	RE	00	87	3.625	50 cm.
RST 1000 Futura	e3*92/61*0057	PW	0	95	4.625	50 cm.

**MARCA: BENELLI****Ciclomotores:**

Denominación Comercial	Contraseña de Homologación	Tipo	Variante	NIVEL SONORO		
				dB (A)	r.p.m.	Distancia
491 RR	CI-1120	BA01	00	72	4.500	7 m.
491 ST	CI-1120	BA01	02	72	4.500	7 m.
K2	CI-1120	BA01	05	72	5.062	7 m.
PePe	CI-1145	BA03	0/0, 0/1	89	5.437	7 m.

**Motocicletas:**

Denominación Comercial	Contraseña de Homologación	Tipo	Variante	NIVEL SONORO		
				dB (A)	r.p.m.	Distancia
VELVET 125	e3*92/61*0004	M1	00/00	83	4.500	50 cm.
VELVET 250	e3*92/61*0008	M7	00/00	88	3.250	50 cm.
ADIVA 125	e3*92/61/0044	D1	00/00	85	4.000	50 cm.
ADIVA 150	e3*92/61/0044	D1	01/00	85	3.750	50 cm.

**MARCA: BETA****Ciclomotores:**

Denominación Comercial	Contraseña de Homologación	Tipo	Variante	NIVEL SONORO		
				dB (A)	r.p.m.	Distancia
QUADRA	CI-1011	BS2	BS3	72	4.875	50 cm.
ARK AG	CI-1073	BS4	00	83	4.900	50 cm.
ARK RD	CI-1073	BS4	01	83	4.900	50 cm.
ARK AR	CI-1073	BS4	02	83	4.900	50 cm.
EIKON	CI-1149	BS5		82	5.625	50 cm.

**MARCA: BETA****Motocicletas:**

Denominación Comercial	Contraseña de Homologación	Tipo	Variante	NIVEL SONORO		
				dB (A)	r.p.m.	Distancia
EIKON 150	e1*92/61*00086*00	S7	00	83	3.800	50 cm.
EIKON 125	e1*92/61*00086*00	S7	01	87	4.000	50 cm.
ALP 200	e1*92/61*00092	T1	00	79	3.875	50 cm.
ALP 125	e1*92/61*00092	T1	01	78	4.625	50 cm.
REVOLUTION 3	e3*92/61*0023*00	B9	00	85	2.875	50 cm.

**MARCA: BETA-TRUEBA****Ciclomotores:**

Denominación Comercial	Contraseña de Homologación	Tipo	Variante	NIVEL SONORO		
				dB (A)	r.p.m.	Distancia
RK 6-T S/M	CI-1012	RK6	SM	87	2.750	50 cm.
RK6-T END.	CI-1012	RK6	00	87	2.750	50 cm.
RR-50 END.	CI-1122	RR		87	3.750	50 cm.
RR-T END.	CI-1122	RR	T0/00	87	2.750	50 cm.
RR-T S/M	CI-1122	RR	T0/S0	87	2.750	50 cm.

**Motocicletas:**

Denominación Comercial	Contraseña de Homologación	Tipo	Variante	NIVEL SONORO		
				dB (A)	r.p.m.	Distancia
SYNT-ALP	A-0515	SY	SP	85	3.000	50 cm.
TECHNO	A-1005	TC		94	2.812	50 cm.

**MARCA: BMW****Motocicletas:**

Denominación Comercial	Contraseña de Homologación	Tipo	Variante	NIVEL SONORO		
				dB (A)	r.p.m.	Distancia
K-100	A-0165	K-100	K-100	85'5	6.000	7 m.
K-100 RS	A-0165	K-100	K-100 RS	85,5	6.000	7 m..
K-100 RT	A-0165	K-100	K-100 RT	85'5	6.000	7 m.
K-100 LT	A-0165	K-100	K-100 LT	85'5	6.000	7 m.
K-75	A-0218	K-75C	K-75	97	4.250	50 cm.
K-75 C	A-0218	K-75C	K-75C	97	4.250	50 cm.
K-75 S	A-0218	K-75C	K-75 S	97	4.250	50 cm.
K-75 RT	A-0218	K-75C	K-75 RT	97	4.250	50 cm.
K-75 RT/TIC	A-0218	K-75C	K-75 RT/TIC	97	4.250	50 cm.
R-65	A-0226	247	R-65	94	5.437	50 cm.
R-65 RT/TIC Policía	A-0226	247	R-65 RT/TIC	94	5.437	50 cm.

**MARCA: BMW****Motocicletas:**

Denominación Comercial	Contraseña de Homologación	Tipo	Variante	NIVEL SONORO		
				dB (A)	r.p.m.	Distancia
R-80	A-0227	247/85	R-80	77'5	4.875	50 cm.
R-80 RT/TIC Policía	A-0227	247/85	R-80 RT/TIC	77'5	4.875	50 cm.
R-80 GS	A-0324	247/E-88	R-80 GS	88	3.250	50 cm.
R-100 GS	A-0325	247/E-88	R-100 GS	89	3.250	50 cm.
R-100 París-Dakar	A-0325	247/E-88	R-100 P/D	89	3.250	50 cm.
R-100	A-0326	247/88	R-100	90	5.250	50 cm.
R-100 RS			100 RS			
R-100 RT/MC Policía			R-100 RT/TIC			
K-1	A-0384	K-1/589	K-100 RS	98	4.000	50 cm.
K-100 RS						
R-80 R	A-0474	247-E-91		90	3.250	50 cm.
R-100 R	A-0475	247-E-91		93	3.250	50 cm.
K-1100 LT	A-0476	K-100 LT-3		94	3.875	50 cm.
		K-1100 LT				
		con y sin catalizador				
R-1100 RS	A-0520	259B	R-1100RS	91	3.625	50 cm.
R-1100 RS	A-0521	K-1100 RS/E3	K-1100RS	94	3.875	50 cm.
R-1100 R	A-0572	R-1100 259 Ext.1	R-1100- R /259	94	3.375	50 cm.
R-1100 GS	A-0572		R-1100GS	94	3.375	50 cm.
R-1100 RT/TIC Policía			R-1100RT / TIC			
R-850 R	A-1017	259	R-850-R /25KW	94	3.750	50 cm.
R-850 GS	A-1017	259	R-850-GS /25KW	94	3.750	50 cm.
R-850R	A-1017	259	0401D/52kW	93	3.500	50 cm.
			0401E/25kW	94	3.750	50 cm.
R-850GS	A-1017	259	0403D/52kW	93	3.500	50 cm.
			0403E/25kW	94	3.750	50 cm.
R-850 R/ ITC Policía	A-1017	259	0401/52kW	93	3.500	50 cm.
R-1100 RT	A-1033	259	R-1100 RT/259	92	3.625	50 cm.
R-1100 RT/TIC Policía						
R-850 RT	A-1046	259	R-850RT /250	92	3.375	50 cm.
R-850 RT/TIC Policía						
F-650	A-1083	F 6	F-650/0162/25kW	85	2.850	50 cm.
F-650 ST	A-1083	F 6	F-650/0163/25Kw	85	2.850	50 cm.
F-650	A-1083	F-6	0162A/35kW	87	3.250	50 cm.
			0162B/25kW	85	2.850	50 cm.

**MARCA: BMW****Motocicletas:**

Denominación Comercial	Contraseña de Homologación	Tipo	Variante	NIVEL SONORO		
				dB (A)	r.p.m.	Distancia
F-650	A-1083	F-6	0163A/35kW	87	3.250	50 cm.
			0163B/25kW	85	2.850	50 cm.
K-1200 RS	A-1101	K 589	0544	93	4.375	50 cm.
R-1200 C	A-1111	R2C	0424	90	3.750	50 cm.
R-1100 S	A-1184	R2S	0422	89	3.750	50 cm.
R-850 c - 37 kW	A-1227	R2C	0421A	85	2.625	50 cm.
R-850 c - 25 kW			0421B	88	3.375	50 cm.
K 1200 LT	e1*92/61*00019*00	K 2LT	0545	89	3.375	50 cm.
R-1150 GS	e1*92/61*00041*00	R 21	0415A	86	3.375	50 cm.
R-1150 R	e1*92/61*00041*01	R 21	0429A	86	3.375	50 cm.
R-850 GS 52 kW	e1*92/61*00041*01	R 21	0414A	86	3.500	50 cm.
R-850 GS 25 kW	e1*92/61*00041*01	R 21	0414B	88	3.750	50 cm.
R-850 R 52 kW	e1*92/61*00041*01	R 21	0428A	86	3.500	50 cm.
R-850 R 25 kW	e1*92/61*00041*01	R 21	0428B	88	3.750	50 cm.
F-650 GS/37KW	e1*92/61*00061*00	R 13	0172A	88	3.250	50 cm.
F-650 GS/25KW	e1*92/61*00061*00	R 13	0172B	86	3.000	50 cm.
F-650 GD 37 kW	e1*92/61*00061*01	R 13	0173A	88	3.250	50 cm.
F-650 GD 25 kW	e1*92/61*00061*01	R 13	0173B	86	3.000	50 cm.
C1	e1*92/61*00066*00	C 1	0191	87	4.625	50 cm.
C1-200	e1*92/61*00066*02	C 1	0192	88	4.250	50 cm.
R-850 C-37 kW	e1*92/61*00093*00	R-2C	0421A	85	2.625	50 cm.
R-850 C-25 kW	e1*92/61*00093*00	R-2C	0421B	88	3.375	50 cm.
R-1200 C Cruiser	e1*92/61*00093*00	R-2C	0424A	90	3.750	50 cm.
R-1200 C-Indep.	e1*92/61*00093*00	R-2C	0405A	90	3.750	50 cm.
R-850 RT	e1*92/61*00101*00	R 22	0417	90	3.625	50 cm.
R-1150 RT	e1*92/61*00101*00	R 22	0419	92	3.625	50 cm.
R 1100 S	e1*92/61*00102*00	R 26	0422	89	3.750	50 cm.
K-1200 -RS 96 kW	e1*92/61*00104*00	K 12	0547A	93	4.375	50 cm.
K-1200 RS 72 kW	e1*92/61*00104*00	K 12	0547B	88	3.500	50 cm.

**MARCA: BULTACO****Ciclomotores:**

Denominación Comercial	Contraseña de Homologación	Tipo	Variante	NIVEL SONORO		
				dB (A)	r.p.m.	Distancia
LOBITO	CI-1147	SENDA		63	3.937	7 m.
ASTRO	CI-1147	SENDA	SENDAB	74	2.810	50 cm.

**MARCA: CAGIVA****Motocicletas:**

Denominación Comercial	Contraseña de Homologación	Tipo	Variante	NIVEL SONORO		
				dB (A)	r.p.m.	Distancia
5N ELEFANT 350	A-0300	5N		83	6.375	50 cm.
			Elefant 350			
CIOR FRECCIA	A-0314	5P - Ext.1	Nueva variante Cior	98	6.562	50 cm.
125 FRECCIA	A-0314	5P-125 Freccia		98	6.562	50 cm.
C12R FRECCIA	A-0314	5P - Ext.2	Cior	98	6.562	50 cm.
			C12R			
4V - 500	A-0318	7N (4V-500)		84	5.500	50 cm.
W12 - 350	A-0334	2N-Ext.1	(I) T4 350E	86	3.500	50 cm.
			(II) W12 350			
T4 - 350 e	A-0334	2N		89	3.500	50 cm.
			(T4 350 E)			
CRUISER	A-0340	4P		86	6.375	50 cm.
			(E4125) (Cruiser)			
E4 125 CRUISER	A-0340	4P - Ext.1	125 Tamanaco	86	6.375	50 cm.
ROADSTER	A-0360	6P-Ext.1	(I) CT125,	91	3.625	50 cm.
			(II) 1A			
CT 125 BLUES	A-0360	6P-CT 125 Blues		93	3.625	50 cm.
COKIS 80	A-0383	1M		94	6.187	50 cm.
MITO 125	A-0442	8P		94	6.750	50 cm.
K 7	A-0443	9P		92	6.000	50 cm.
900 ELEFANT	A-0444	1B		97	6.000	50 cm.
906 ELEFANT	A-0444	1B-Ext.1	5B	90	3.250	50 cm.
SM 125	A-0483	2F		101	6.000	50 cm.
W 8 - 125	A-0484	9PE - Ext.1	A8	85	3.750	50 cm.
W 8 - 125	A-0484	9PE		100	6.375	50 cm.
SUPER CITY 75	A-0509	1F		83	4.250	50 cm.
4V 600	A-1018	2G		93	3.625	50 cm.
RIVER 600	A-1034	3G		90	3.000	50 cm.
PLANET 125	A-1166	N1	00/AA	93	6.750	50 cm.
CANYON	A-1167	M1	00/AA	88	3.250/3.125	50 cm.
			00/AB			
GRAN CANYON	A-1198	M3	00/AA	88	3.500	50 cm.
RIVER 500	A-1251	3G/F	01/AA,	93/91	3.600/3.500	50 cm.
			01/AB			
			AA.L			
RAPTOR 650	e3*92/61*0018*01	M2	10/AC, 11/AC	86	4.500	50 cm.
V-RAPTOR 650	e3*92/61*0018*01	M2	10/AC, 11/AC	86	4.500	50 cm.

**MARCA: CAGIVA****Motocicletas:**

Denominación Comercial	Contraseña de Homologación	Tipo	Variante	NIVEL SONORO		
				dB (A)	r.p.m.	Distancia
RAPTOR 1000	e3*92/61*0018*01	M2	00/AA 00/AB 01/AA, 01/AB	96	4.250	50 cm.
V-RAPTOR 1000	e3*92/61*0018*01	M2	00/AA, 00/AB 01/AA, 01/BB	96	4.250	50 cm.
NAVIGATOR 1000	e3*92/61*0032*01	M5	00/AA	91	4.250	50 cm.

**MARCA: DERBI****Ciclomotores:**

Denominación Comercial	Contraseña de Homologación	Tipo	Variante	NIVEL SONORO		
				dB (A)	r.p.m.	Distancia
VARIANT TOP	CI-0013	Varian	Variant Top	85	4.125	7 m.
VARIANT CALIFORNIA	CI-0013	Variant California		71	4.125	7 m.
VARIANT SLE X	CI-0013	Variant SLE-X		78'5	4.125	7 m.
VARIANT START	CI-0013	Variant Start		77'8	4.125	7 m.
VARIANT START 14	CI-0013	Variant Start 14		79'5	4.125	7 m.
VARIANT START ELECTRIC	CI-0013	Variant Ext.5	Variant Start Electric	74	4.125	7 m.
SPORT WORLD CHAMPION	CI-0013	Variant Ext.4	Sport World Champion	72	4.125	7 m.
VARIANT START WORLD CHAMPION	CI-0013	Variant Ext.6	Variant Start World Champion	69	4.125	7 m.
VARIANT SLE AMERICA	CI-0014	Variant SLE America		66	4.125	7 m.
VARIANT SPORT	CI-0015	Variant Sport		75	4.125	7 m.
DS50 WORLD CHAMPION	CI-0016	START DS50	World Champion	68	4.125	7 m.
START 05-50	CI-0016	START DS50		66'7	4.125	7 m.
YUMBO SUPER FD	CI-0017	Yumbo Super FD		72'2	4.350	7 m.
COPPA FDT	CI-0022	COPPA FDT		70	4.162	7 m.
FDX	CI-0022	FDX		87	3.637	50 cm.
RD 2	CI-0024	RD 2		70	4.350	7 m.
FT 50	CI-0025	FT50		73'5	4.125	7 m.
FDS	CI-0034	FDS		94	4.350	50 cm.
FDS SAVANNAH-E	CI-0034	FDS	FDS Savannah FDS Savannah E	74	4.350	7 m.
FDS SAVANNAH	CI-0034	FDS Ext.1	FDS Savannah	73	4.350	7 m.
FDS 50 SUPER	CI-0034	FDS Ext.	FDS 50 SUPER	71	4.312	7 m.

**MARCA: DERBI****Ciclomotores:**

Denominación Comercial	Contraseña de Homologación	Tipo	Variante	NIVEL SONORO		
				dB (A)	r.p.m.	Distancia
COUNTRY	CI-0073	Country		72	3.750	7 m.
VAMOS	CI-0092	VAMOS		71	4.500	7 m.
VAMOS	CI-0092	VAMOS Ext.1	R-I	71	4.500	7 m.
VARIANT BOX	CI-0093	Variant Box		69	4.500	7 m.
VARIANT SPORT R	CI-0094	Variant Sport-R		69	4.125	7 m.
SENDA	CI-0104	SENDA H		65	4.125	7 m.
FENIX	CI-0105	FENIX H		66	4.125	7 m.
GPR 50	CI-1004	GPR50H		78	3.937	7 m.
URBAN	CI-1005	URBAN F		93	3.750	50 cm.
SENDA	CI-1006	SENDA G		77	3.750	7 m.
SENDA SM	CI-1006	SENDA G	SENDA R SEND BA	62	4.500	7 m.
SENDA	CI-1006	SENDA G	SENDA R	61'2	3.940	7 m.
CAMPERA	CI-1006	SENDA G	SENDA R Ext.3 SEND BA SEND DA	69	4.125	7 m.
VAMOS	CI-1020	VAMOS H		62	4.630	7 m.
VAMOS	CI-1020	VAMOS H	VAMOS FL	62	4.630	7 m.
FENIX	CI-1032	FENIX G		69	4.125	7 m.
FURAX	CI-1035	FURAX F		65	3.750	7 m.
VARIANT START WORLD CHAMPION	CI-1036	VRN95F		65	3.750	7 m.
SPORT	CI-1036	VRN95F Ext.2	VRN95F 96 VRN95F 97	69	3.750	7 m.
REVOLUTION	CI-1036	VRN95F Ext.3	VRN95F 96 VRN95F 97 VRN95F C	67	3.750	7 m.
VARIANT START WORLD CHAMPION	CI-1036	Ext.1		65	3.750	7 m.
HUNTER	CI-1059	Hunter		64	4.125	7 m.
PADDOCK	CI-1059	Hunter	HUNT-I	61	4.125	7 m.
PADDOCK	CI-1059	Hunter	HUNT II	62	4.125	7 m.
MANHATTAN	CI-1059	Hunter	Hunter	61	4.125	7 m.
EASY	CI-1060	EASY	VRN95F 96	68	4.875	7 m.
GPR 50 R	CI-1102	GPRR		62	3.190	7 m.
PREDATOR	CI-1128	PRED	PREDAB	62	3.937	7 m.
PREDATOR	CI-1128	PRED Ext.1	PREDAB REDAA	62	3.937	7 m.
GPI	CI-1128	PRED	PREDSB	81	3.625	50 cm.

**MARCA: DERBI****Ciclomotores:**

Denominación Comercial	Contraseña de Homologación	Tipo	Variante	NIVEL SONORO		
				dB (A)	r.p.m.	Distancia
ATLANTIS	CI-1156	ATL	ATL0AA	80	3.375	50 cm.
ATLANTIS LC	CI-1156	TL	ATL0AB	80	3.375	50 cm.
SENDA R	CI-1165	Sdr	SDR1AB	76	3.375	50 cm.
SM	CI-1165	SDR	SDR1BB	78	3.375	50 cm.
BOX	CI-1177	BX	BX1AA1	86	3.750	50 cm.
VARIANT	CI-1178	VR	VR1AA1	86	3.750	50 cm.
VARIANT SPORT	CI-1178	VR	VR1AA1	86	3.750	50 cm.

**Motocicletas:**

Denominación Comercial	Contraseña de Homologación	Tipo	Variante	NIVEL SONORO		
				dB (A)	r.p.m.	Distancia
SCOOT-DERBI	A-0125	Scoot 74 cc		70	4.875	7 m.
EUROPA 75	A-0126	Europa 75 c.c.		70	5.100	7 m.
TT-8	A-0141	TT-8		71	4.875	7 m.
T-250 6-V	A-0154	T250 6V		70	4.800	7 m.
GPR 75 SPORT	A-0391	GPR 75H	GPR 75H (91)	92	6.750	50 cm.
		Ext.1				
GPR 75	A-0391	GPR 75H		92	6.750	50 cm.
TRAIL BI 3	A-0451	BI 3-75H		95	7.500	50 cm.
PANTHER CA-64	A-0463	CA		90	4.321	50 cm.
VIVO	A-0464	KP		97	4.875	50 cm.
ATLANTIS 100	e9*92/61*0049	AT	AT1A1A	82	3.500	50 cm.

**MARCA: GAS GAS****Ciclomotores:**

Denominación Comercial	Contraseña de Homologación	Tipo	Variante	NIVEL SONORO		
				dB (A)	r.p.m.	Distancia
ENDUCROSS	e9*92/61*0044*00	EC50	EC50	79	3.250	50 cm.
ROOKIE 50						

**Motocicletas:**

Denominación Comercial	Contraseña de Homologación	Tipo	Variante	NIVEL SONORO		
				dB (A)	r.p.m.	Distancia
ENDUCROSS 125	A-0552	EC 125	EC12	90	4.750	50 cm.

**MARCA: GAS GAS****Motocicletas:**

Denominación Comercial	Contraseña de Homologación	Tipo	Variante	NIVEL SONORO		
				dB (A)	r.p.m.	Distancia
ENDUCROSS 250	A-1006	EC 25	EC25(I)/-	99	3.750	50 cm.
ENDUCROSS 250	A-1006	EC 25	EC25(I) / EC25 K	99	3.750	50 cm.
ENDUCROSS 200	A-1006	EC 25	EC20 / -	96	3.750	50 cm.
ENDUCROSS 200	A-1006	EC 25	EC20 / EC20 K	96	3.000	50 cm.
ENDUCROSS 300	A-1006	EC 25	EC30 / -	91	4.500	50 cm.
ENDUCROSS 300	A-1006	EC 25	EC30 / EC30 K	91	4.500	50 cm.
CONTACT	A-1057	GG 12	GG12	90	3.000	50 cm.
CONTACT	A-1058	GG 14	GG14	85	3.000	50 cm.
CONTACT	A-1059	GG 16	GG16	85	3.000	50 cm.
CONTACT	A-1060	GG 25	GG25	98	3.000	50 cm.
CONTACT	A-1061	GG 27	GG27	98	3.000	50 cm.
CONTACT	A-1062	GG 37	GG37	99	3.500	50 cm.
PAMPERA 125	A-1114	PP	PP12	80	3.500	50 cm.
PAMPERA 200	A-1114	PP	PP20	80	3.500	50 cm.
PAMPERA 250	A-1114	PP	PP25	81	4.000	50 cm.
PAMPERA 320	A-1114	PP	PP32	80	2.750	50 cm.
ENDUCROSS 125	e9*97/24/9*4326*00	EC 125	EC125	85	3.553	50 cm.
SUPERMOTARD 125	e9*97/24/9*4326*00	EC 125/S	SM125	85	3.553	50 cm.
ENDUCROSS 200	e9*97/24/9*4103*01	EC 200	EC200	96	3.850	50 cm.
SUPERMOTARD 200	e9*97/24/9*4103*01	EC 200/S	SM200	96	3.850	50 cm.
ENDUCROSS 250	e9*97/24/9*4327*00	EC250	EC250	99	3.750	50 cm.
SUPERMOTARD 250	e9*97/24/9*4327*00	EC 250/S	SM250	99	3.750	50 cm.
ENDUCROSS 300	e9*97/24/9*4133*01	EC300	EC300	91	4.500	50 cm.
SUPERMOTARD 300	e9*97/24/9*4133*01	EC 300/S	SM300	91	4.500	50 cm.
TRIAL 120	e9*92/61*0083*00	GG 120/2	GG12/GG12K	86	2.750	50 cm.
TRIAL 160	e9*92/61*0083*00	GG 160/2	GG16/GG16K	89	2.750	50 cm.
TRIAL 250	e9*92/61*0083*00	GG 250/2	GG25/GG25K	86	3.750	50 cm.
TRIAL 280	e9*92/61*0083*00	GG 280/2	GG28/GG28K	94	3.750	50 cm.
ENDUCROSS 400 FSE	e9*92/61*0081*00	FS 40	FS40	91	4.000	50 cm.

**MARCA: GILERA****Ciclomotores:**

Denominación Comercial	Contraseña de Homologación	Tipo	Variante	NIVEL SONORO		
				dB (A)	r.p.m.	Distancia
GILERA 50 RT	CI-0080	135E	----	78	7.000	7 m.
GILERA 50 R	CI-0100	2001	----	72	8.500	7 m.
GILERA TWIN - 6V						
GILERA TWIN - PRO	CI-1013	2003	----	72	6.375	7 m.

**MARCA: GILERA****Ciclomotores:**

Denominación Comercial	Contraseña de Homologación	Tipo	Variante	NIVEL SONORO		
				dB (A)	r.p.m.	Distancia
GILERA 50 - CANNIBAL	CI-1039	2301	I	74	3.315	7 m.
GILERA 50 - CANNIBAL	CI-1039	2301	II	74	3.315	7 m.
GILERA 50 - SURFER	CI-1039	2301	III	74	3.315	7 m.
GILERA 50 - EAGLET	CI-1040	086	I	70	3.187	7 m.
GILERA 50 - EAGLET MY			II			
EAGLET AUTOMATICA	CI-1077	C09	1	69	4.687	7 m.
STALKER	CI-1090	C13	----	82	5.250	50 cm.
RUNNER	CI-1091	C14	1	86	4.125	50 cm.
50 H@K	e9*92/61*0022*00	C08	110	90	4.000	50 cm.
50 GSM			112			
DNA-50	e9*92/61*0040*00	C27	100	77	3.500	50 cm.
ZULÚ	e9*92/61*0061*00	C33	100	82	3.250	50 cm.

**Ciclomotores:**

Denominación Comercial	Contraseña de Homologación	Tipo	Variante	NIVEL SONORO		
				dB (A)	r.p.m.	Distancia
125 TG.1 MIX	A-0077	125 TG.1	-----	88	5.400	50 cm.
125 TG.3	A-0116	125 TG.3	----	88	5.400	50 cm.
RV 200	A-0213	RV 200	----	86	5.500	50 cm.
RV 200 ES						
RX 200	A-0214	RX 200	----	87	5.600	50 cm.
RX 200 ES						
RX ARIZONA 200						
RX ARIZONA 200 ES						
RV 125	A-0233	RV 125	----	83	5.500	50 cm.
RV 125 ES						
RX 125	A-0234	RX 125	RX 125	86	5.600	50 cm.
RX 125 ES			ARIZONA			
RX 125 ARIZONA						
RX 125 ES ARIZONA						
250 RALLY	A-0247	250 RALLY	250 RALLY	94	5.500	50 cm.
250 RALLY RC			RC			
NGR 250	A-0248	NGR 250	----	94	5.500	50 cm.
KZ 125	A-0277	KZ 125	I	88	4.500	50 cm.
KZ 125 ES			II			
ZZ 125			III			
KK 125						
ZZ 125-ES			IV			
KK 125-ES						

**MARCA: GILERA****Motocicletas:**

Denominación Comercial	Contraseña de Homologación	Tipo	Variante	NIVEL SONORO		
				dB (A)	r.p.m.	Distancia
350 DAKOTA	A-0278	350 DAKOTA	----	90	3.720	50 cm.
350 DAKOTA ES						
350 DAKOTA ES						
500 DAKOTA	A-0302	500 DAKOTA	----	92	3.500	50 cm.
500 ER			500 ER			
125 RRT	A-0303	125 RRT	----	85	4.375	50 cm.
125 FB			125 FB			
125 MX1	A-0362	125 MX1	----	87	5.765	50 cm.
125 MX1 ELESTART			125 MX1 ELESTART			
125 MXR						
125 MXR ELESTART						
XR1 125	A-0363	125 XR1	----	83	4.750	50 cm.
XR1 125 ELESTART			XR1 125 ELESTART			
XR2						
600 XRT	A-0376	600 XRT	600 XRT	88	3.625	50 cm.
600 XRT ELESTART			ELESTART			
500 SATURNO	A-0377	500 SATURNO	----	86	3.625	50 cm.
500 SATURNO ELESTART			500			
			SATURNO			
			ELESTART			
SP01	A-0399	152	----	87	4.650	50 cm.
SP01 ELESTART						
SP-02			SP-02			
125RC	A-0400	154		88	5.375	50 cm.
125RC ELESTAR						
125C		156, 125 C				
125FB		156,				
125R		125FB				
		160, 125R				
RC-600	A-0401	226	----	89	5.438	50 cm.
RC-600 ELESTRART			600C			
			600R			
			600FB			
			600R a.e			
125 SP/E CRONO	A-0452	164 (125 SP)	----	99	5.600	50 cm.
125 CX	A-0453	158	----	99	5.500	50 cm.
125 GFR	A-0549	167	----	92	5.375	50 cm.
350 FB	A-0550	234	----	88	3.750	50 cm.
RUNNER 125	A-1134	M07	1	76	3.500	50 cm.

**MARCA: GILERA****Motocicletas:**

Denominación Comercial	Contraseña de Homologación	Tipo	Variante	NIVEL SONORO		
				dB (A)	r.p.m.	Distancia
RUNNER 180	A-1135	M08	1	89	4.000	50 cm.
COGUAR 125 4T	A-1234	M17	100	85	4.125	50 cm.
DNA-180	e3*92/61*0065*03	M26	200	87	4.875	50 cm.

**MARCA: HONDA****Ciclomotores:**

Denominación Comercial	Contraseña de Homologación	Tipo	Variante	NIVEL SONORO		
				dB (A)	r.p.m.	Distancia
PX50, PX50S, PXR50	CI-0001	AB05	PX50 PX50S, PXR50	81	7.000	7 m.
PK50, PK50S	CI-0068	AB24	PK50, PK50S	77	4.350	7 m.
NE 50	CI-0069	AF09		60	4.025	7 m.
DIO	CI-0096	AF27		69	5.250	7 m.
SFX 50	CI-1029	AF37		65	5.250	7 m.
SFX 50	CI-1029	AF37	AF37'98	65	5.250	7 m.
SFX 50	CI-1029	AF37	AF37'97	65	5.250	7 m.
SH 50	CI-1030	SH50		61	3.750	7 m.
SJ 50	CI-1037	AF32		69	5.062	7 m.
CRM 50 K	CI-1052	AD12		73	3.375	50 cm.
NSR 50 R	CI-1064	AC14		60	3.000	7 m.
SH 50	CI-1066	AF40	AF40'98	61	5.062	7 m.
SH 50	CI-1066	AF40		61	5.062	7 m.
SGX 50	CI-1089	AF43		67	4.875	7 m.
SHADOW 50	CI-1098	AF42		66	4.500	7 m.
SZX50S / SZX50X	CI-1115	AF49		71	5.437	7 m.

**Motocicletas:**

Denominación Comercial	Contraseña de Homologación	Tipo	Variante	NIVEL SONORO		
				dB (A)	r.p.m.	Distancia
ST 70 DAX	A-0042	ST70	Nueva curva Ext.1 potencia / sist.escape carb. y horquilla del.	78	4.000	50 cm.
VF 750 F	A-0150	RC15. VF750F		83'5	7.500	50 cm.
CBX 550 F2	A-0151	PD04. CBX550F CBX550F2		79'5	7.500	50 cm.
CB 1100 R	A-0164	SC08. CB1100R		83	6.750	50 cm.
CX 650 TURBO	A-0173	RC16. CX650 Turbo		85	6.750	50 cm.

**MARCA: HONDA****Motocicletas:**

Denominación Comercial	Contraseña de Homologación	Tipo	Variante	NIVEL SONORO		
				dB (A)	r.p.m.	Distancia
LEAD 125	A-0175	NH125. Lead 125		74	5.250	7 m.
CBX 750 F	A-0184	RC17. CBX750F		83	7.125	50 cm.
VF 1000 R	A-0185	SC16. VF1000R		102	7.500	50 cm.
SH 80	A-0190	SH80. Scoopy		67	4.500	7 m.
XL 200 R PARIS DAKAR	A-0192	MD06. XL200R XL200R Paris Dakar	MD06-A.	86'5	4.000	50 cm.
XL 200 R PARIS DAKAR	A-0192	MD06. XL200R Ext. 1 SL200R-P/D. Ext.1 Freno del. disco hidráulico	MD06-A.	86'5	4.000	50 cm.
CB 450 S	A-0219	PC17. CB450S		88	4.500	50 cm.
VFR 750 F II	A-0220	RC24. VFR750F Ext.1 VFR750F	RC24 (88)	93	5.250	50 cm.
VFR 750 F	A-0220	RC24. VFR750F		95	5.250	50 cm.
VF 1000 F II	A-0221	SC24. VF1000FII		94	5.000	50 cm.
NS 125 F	A-0222	TC01. NS125F		106	7.500	50 cm.
NS 125 F II	A-0222	TC01. SN125F Ext. 1 NS125R con carenado integral	Ext.1	106	7.500	50 cm.
XL 125 PARIS DAKAR	A-0223	TD01-A. XL125 Paris-Dakar		85	6.750	50 cm.
XL 125 PARIS DAKAR	A-0223	TD01-A. XL125 Paris-Dakar Cambio Sist. Freno del., freno disco hidráulico	Ext. 1	85	6.750	50 cm.
GL 1200 GOLDWING ASPENCADE	A-0259	SC14. GL1200 Goldwing Goldwing Aspencade	GL1200	92	3.500	50 cm.
MTX 125 R	A-0261	TC02. MTX125R		89	4.250	50 cm.
MTX 125 R	A-0261	TC02. Ext. 1 por nuevo carenado: MTX125R2	Variante	89	4.250	50 cm.
CBR 600 F	A-0266	PC19. CBR600F		92	5.500	50 cm.
CBR 1000 F	A-0267	SC21. CBR1000F		96	4.750	50 cm.
TRANSALP 600 V	A-0268	PD06. Ext. 1	PD06 (91)	85	4.000	50 cm.
TRANSALP 600 V	A-0268	PD06. Ext. 2	PD06 (91) PD06 (96)	85	4.000	50 cm.



## MARCA: HONDA

## Motocicletas:

Denominación Comercial	Contraseña de Homologación	Tipo	Variante	NIVEL SONORO		
				dB (A)	r.p.m.	Distancia
TRANSALP 600 V	A-0268	PC06. Transalp 600V		85	4.000	50 cm.
TRANSALP 600 V	A-0268	PD06. Ext. 3	PD06 (91) PD06 (96) PD0696L	83	3.500	50 cm.
CG 125	A-0270	CG125BR CG 125		89	6.000	50 cm.
GL 1500 GOLDWING GL 1500 GOLDWING (99) (GL 1500 GOLDWING)	A-0320	SC22.		83/81	2.600/2.600	50 cm.
VFR 750 R	A-0321	RC 30 (VFR 750 R)		104	5.500	50 cm.
NX 650	A-0322	RD02. Ext. 3	RD02(91) RD02(92), RD08	86	3.000	50 cm.
NX 650 DOMINATOR	A-0322	RD02. NX650		91	3.000	50 cm.
NX 650	A-0322	RD02. Ext. 4	RD02(91) RD02(92) RD08, RD08(L)	84	2.750	50 cm.
NX 650 DOMINATOR	A-0322	RD02. Ext. 2	RD02(91) RD02(92)	88	3.000	50 cm.
NX 650 DOMINATOR	A-0322	RD02. Ext. 1	RD02 (91)	86	3.000	50 cm.
NSR 75 F	A-0323	DC02. NSR75F		68'5	7.125	7 m.
NSR 75 F II	A-0323	DC02. Ext. 1	Nueva variante: NSR75F SNSR75F II	68'5	7.125	7 m.
NTV 650	A-0329	RCC33. Erxt. 2	RC33(91) RC33(93)	90	3.750	50 cm.
NTV 650	A-0329	RC33 NTV650		92	3.750	50 cm.
NTV 650	A-0329	RC33. Ext. 1	RC33 (91)	90	3.750	50 cm.
CB 450 N	A-0332	PC14. CB450N		89	4.500	50 cm.
NX 250	A-0333	MD21. NX250		91	4.250	50 cm.
CBR 600 F	A-0344	PC23. CBR600FR		93	5.500	50 cm.
XLX 350 R	A-0345	ND04. XLX350R		84	3.625	50 cm.
NSR 125 F	A-0346	JC20. NSR125F	Nueva Ext.1 variante con carenado completo: NSR125R	88	7.125	50 cm.
NSR 125 F	A-0346	JC20. NSR125F		88	7.125	50 cm.
CBR 1000 F	A-0351	SC24. CBR1000F		92	4.750	50 cm.
CBR 1000 F	A-0351	SC24. CBR1000F	SC24 (93)	92	4.750	50 cm.



## MARCA: HONDA

## Motocicletas:

Denominación Comercial	Contraseña de Homologación	Tipo	Variante	NIVEL SONORO		
				dB (A)	r.p.m.	Distancia
CBR 1000 F	A-0351	SC24. Ext. 2	SC24 (93) SC24 (96)	92	4.750	50 cm.
XBR 500	A-0358	PC15. XBR500		94	3.500	50 cm.
CRM 75 R	A-0364	DD02. CRM75R		80	4.250	50 cm.
VISION MET-IN	A-0365	DP02		83	3.250	50 cm.
CRM 125 R	A-0393	JD10. CRM125R		87	4.750	50 cm.
ST 70 DAX	A-0395	DB01. ST70 DAX		78	4.000	50 cm.
XRV 750 AFRICA TWIN	A-0397	RD04 XRV750 Africa Twin		89	4.000	50 cm.
VFR 750 F	A-0398	RC36. VFR750F		89	5.000	50 cm.
ST 1100 PANEUROPEAN	A-0406	SC26. Ext. 1	SC26B	90	3.750	50 cm.
ST 1100 PANEUROPEAN	A-0406	SC26 ST1100 Pan European		92	3.750	50 cm.
XR 600 R	A-0421	PE04. Ext. 1	PE04 (91)	88	3.375	50 cm.
XR 600 R	A-0421	PE04. XR600R		88	3.375	50 cm.
VT 600 C SHADOW	A-0422	PC21 VT600C Shadow		93	3.250	50 cm.
VT 600 C SHADOW	A-0422	PC21. Ext. 1	PC21 (96)	91	3.250	50 cm.
VT 600 C SHADOW	A-0422	PC21. Ext. 2	PC21 (96) PC21 (96) (L)	90	3.250	50 cm.
NX 250	A-0424	MD25. NX250		83	4.000	50 cm.
NH 90 YUPI	A-0425	HF05. NH90 YUPI		84	3.500	50 cm.
CBR 600 F	A-0438	PC25. CBR600F		90	6.000	50 cm.
CRM 125 R	A-0466	JD15. CRM125R / JD15(L)		89/86	4.250/3.625	50 cm.
CB TWO FIFTY	A-0485	MC26		84	4.500	50 cm.
CB SEVEN FIFTY	A-0491	RC42		90	4.250	50 cm.
CBR 900 RR	A-0492	SC28 CBR900RR		91	5.250	50 cm.
NS-1	A-0495	DC03		83	4.875	50 cm.
CRM 75 R	A-0498	DD02 '92. CRM75R		80	4.250	50 cm.
4NR 750	A-0500	RC40. NR750		95	7.000	50 cm.
NSR 125 F, NSR 125 R	A-0527	JC22. NSR125F, NSR125R		88	5.000	50 cm.
NSR 125 F, NSR 125 R	A-0527	JC22. Ext. 1	NSR125F NSR125R NSR125F (L) NSR125R (L)	80	3.625	50 cm.
CB 1000 F	A-0528	SC30		90	4.250	50 cm.
XRV 750, SRV 750 (96)	A-0529	RD07. XRV 750		87/84	3.750/3.750	50 cm.



## MARCA: HONDA

## Motocicletas:

Denominación Comercial	Contraseña de Homologación	Tipo	Variante	NIVEL SONORO		
				dB (A)	r.p.m.	Distancia
VF 750 C	A-0544	RC43. VF750C		90	4.500	50 cm.
VF 750 C (L)	A-0544	RC43. Ext.2	RC43 (L)	87	3.125	50 cm.
VF 750 C	A-0544	RC43. Ext.1	RC43 (V)	90	4.500	50 cm.
CB 500	A-0554	PC26. CB500		87	4.750	50 cm.
SHADIW	A-0555	SC23		97	3.750	50 cm.
VFR 750 F	A-0570	RC36-4		87	5.000	50 cm.
RVF 750 R	A-0571	RC45		94	6.000	50 cm.
CRE 125	A-0585	JE01T. Ext.1		85	3.250	50 cm.
CRE 125	A-0585	JE01T		85	3.250	50 cm.
CRE 250	A-0586	ME03T		90	2.750	50 cm.
CRE 250	A-0586	ME03T. Ext.1	Neumático trasero, carburador ct. reglamento parcial	90	2.750	50 cm.
CBR 600 F (L)	A-1009	PC31. Ext.1	PC31 (L)	87	4.500	50 cm.
CBR 600 F	A-1009	PC31. Ext.2	PC31'97,	90/86	6.000/4.500	50 cm.
CBR 600 F (L)			PC31 (L) '97			
CN 250	A-1010	MF02		82	3.250	50 cm.
CA 125	A-1011	JC24		82	4.750	50 cm.
VT 1100 C	A-1020	SC32		88	3.000	50 cm.
CMX 250 C	A-1036	MC13. CMX250C		83	4.125	50 cm.
CBR 900 RR	A-1042	SC33		92	5.250	50 cm.
SJ 100	A-1043	HF07. SJ100. Ext.1	HF07 '97	89	3.375	50 cm.
SJ 100	A-1043	HF07		88	3.375	50 cm.
CB 500	A-1051	PC32		86	4.750	50 cm.
CB500	A-1051	PC32. Ext. 3	PC32'98,	86	4.750	50 cm.
CB 500 S			PC32L'98 (ambas con y sin cúpula)			
CB 500	A-1051	PC32. Ext. 1	PC32 (L)	85	4.250	50 cm.
CB 500	A-1051	PC32. Ext. 2	PC32'97	85	4.250	50 cm.
CB 500	A-1051	PC32	PC32 (L) '97	86	4.750	50 cm.
XR 400 R	A-1066	NE03		90	3.125	50 cm.
CBR 1100 XX,	A-1069	SC35		91/90	5.000/4.750	50 cm.
CBR 1100 XX ('99)						
SH 100	A-1070	HF08		82	3.250	50 cm.
SLR 650	A-1073	RD09	RD09 (L)	90/85	3.565/2.875	50 cm.
SLR 650 (L)						



## MARCA: HONDA

## Motocicletas:

Denominación Comercial	Contraseña de Homologación	Tipo	Variante	NIVEL SONORO		
				dB (A)	r.p.m.	Distancia
FX 650	A-1073	RD09		85	2.875	50 cm.
GL 1500 C	A-1074	SC34		87	3.000	50 cm.
SPACY 125	A-1081	JF03		84	3.750	50 cm.
CMX 250 C	A-1092	MC32		84	4.000	50 cm.
CA 125	A-1093	JC26		83	4.750	50 cm.
VFR 750 F	A-1095	SC36		87	5.000	50 cm.
VT 750 C	A-1096	RC44		88	2.750	50 cm.
TRANSALP 600 V, TRANSALP 600 V (L)	A-1097	PD10	PD10 (L)	86/85	4.000/3.500	50 cm.
CRE 250	A-1105	ME03		90/86	2.750/2.750	50 cm.
CRE 250 ('97)						
SHADOW 90	A-1107	HF09		84	3.375	50 cm.
FORESIGHT	A-1109	MF04		83	3.500	50 cm.
XLR 125 R	A-1117	JD16		77	4.125	50 cm.
VFR 800 F	A-1126	RC46		88	5.250	50 cm.
CB 600 F	A-1131	PC34	PC34L	92/84	6.000/4.000	50 cm.
CB 600 F (L)						
VT 1100 C3	A-1136	SC39		90	3.562	50 cm.
NT 650 V	A-1139	RC47	RC47 (L)	88	3.500	50 cm.
PANTHEON 125	A-1151	JF05		80	3.500	50 cm.
PANTHEON 150	A-1152	KF02		82	3.500	50 cm.
XR 250 R	A-1160	ME08		84	3.000	50 cm.
CRE 125 R	A-1162	JE01		85	3.250	50 cm.
CLR 125	A-1173	JD18		82	4.125	50 cm.
CBR 600 F, CBR 600 F (L)	A-1194	PC35	PC35 (L)	91/88	6.250/4.500	50 cm.
VTR 250	A-1196	MC33		86	5.250	50 cm.
CHA 125	A-1202	JF04		81	3.750	50 cm.
XR 650 R	A-1242	RE01		90	3.563	50 cm.
CRE 250	A-1255	ME03		86	2.750	50 cm.
CBR 900 RR	e13*92/61*0019	SC44		94	5.500	50 cm.
CB 600	e13*92/61*0020	PC34		91	6.000	50 cm.
CB 600 S	e13*92/61*0020	PC34		91	6.000	50 cm.
CBR 1100 XX	e13*92/61*0043	SC35		90	4.750	50 cm.
VTR 1000 F	e13*92/61*0061	SC36		91	4.750	50 cm.
FES 250	e3*92/61*0011	MF05		85	3.500	50 cm.
XL 650 V	e3*92/61*0017	RD10		85	3.750	50 cm.
NSS 250	e3*92/61*0054	MF07		83	3.500	50 cm.
SH 125	e3*92/61*0073	JF09		83	4.500	50 cm.

**MARCA: HONDA****Motocicletas:**

Denominación Comercial	Contraseña de Homologación	Tipo	Variante	NIVEL SONORO		
				dB (A)	r.p.m.	Distancia
SH 150	e3*92/61*0074	KF04		85	4.500	50 cm.
XL 1000 V	e4*92/61*0009	SD01		91	4.750	50 cm.
CB 1100 SF	e4*92/61*0026	SC42		91	4.500	50 cm.
VT 1100 C2	e4*92/61*0062	SC43		93	2.750	50 cm.
NES 125	e4*92/61*0082	JF07		86	4.500	50 cm.
NES 150	e4*92/61*0083	KF03		85	4.250	50 cm.
VT 750 DC	e4*92/61*0085	RC48		91	2.750	50 cm.
CBR 600 F	e4*92/61*0101	PC35		91	6.250	50 cm.
CBR 600 FS	e4*92/61*0101	PC35		91	6.250	50 cm.
VF 750 C	e4*92/61*0102	RC44		88	2.750	50 cm.
GL 1500	e4*92/61*0107	SC22		85	2.600	50 cm.
GL 1800	e4*92/61*0113	SC47		97	3.750	50 cm.
VTX 1800	e4*92/61*0113	Sc46		97	3.750	50 cm.
FJS 600	e4*92/61*0114	PF01		87	3.500	50 cm.
VT 125 C	e9*92/61*0043	JC31		85	5.500	50 cm.
XL 125 V	e9*92/61*0053	JC32		84	5.500	50 cm.
XL 1000 V	e9*92/61*0059	SD02		91	4.000	50 cm.
NT 650 V	e9*92/61*0073	RC47		91	3.875	50 cm.

**MARCA: HUSABERG****Motocicletas:**

Denominación Comercial	Contraseña de Homologación	Tipo	Variante	NIVEL SONORO		
				dB (A)	r.p.m.	Distancia
FE-400	e5*92/61*0001	FE	400	87	3.675	50 cm.
FE-501	e5*92/61*0001	FE	501	88	3.675	50 cm.
FE-650	e5*92/61*0001	FE	400	87	2.600	50 cm.

**MARCA: HUSQVARNA****Motocicletas:**

Denominación Comercial	Contraseña de Homologación	Tipo	Variante	NIVEL SONORO		
				dB (A)	r.p.m.	Distancia
125 WR	A-1030	1A1		89	6.000	50 cm.
610 TE	A-1206	H7	AA/00, AA/01	89	3.550	50 cm.
610 SM			AA/02, AB/00 AB/01, AB/02			
250 WR	A-1207	H2	00/AA, 00/AB	78	2.625	50 cm.
TE-410	A-1045	2AA		84	3.625	50 cm.

**MARCA: HYOSUNG****Ciclomotores:**

Denominación Comercial	Contraseña de Homologación	Tipo	Variante	NIVEL SONORO		
				dB (A)	r.p.m.	Distancia
SUPER CAB 50 PLUS	CI-1118	SB 50		62	4.125	7 m.
SENSE 50	CI-1119	SD 50		65	4.350	7 m.
SF 50	CI-1168	SF 50		83	3.500	50 cm.

**Motocicletas:**

Denominación Comercial	Contraseña de Homologación	Tipo	Variante	NIVEL SONORO		
				dB (A)	r.p.m.	Distancia
CRUISE GA 125 II	A-1156	GA125P		82	4.400	50 cm.
CAB 100	A-1157	EZ-100		76	3.100	50 cm.
GF-125	A-1158	GP-125		81	4.300	50 cm.
GRAND PRIX 125	A-1168	GPS125		84	4.200	50 cm.
RX 125	e4*92/61*0032*00	RX 125	A, B	83/81	4.250	50 cm.
GV 125	e4*92/61*0079	GV 125		84	5.150	50 cm.
GV 250	e4*92/61*0097	GV 250		84	4.600	50 cm.

**MARCA: ITALJET****Motocicletas:**

Denominación Comercial	Contraseña de Homologación	Tipo	Variante	NIVEL SONORO		
				dB (A)	r.p.m.	Distancia
FORMULA 50	CI-1024	FR 50		60	3.750	7 m.
FORMULA 50	CI-1104	FRH	FRH1BS	60	3.750	7 m.
DRAGSTER	CI-1136	DRG		66	4.500	7 m.
TORPETO	CI-1141	TR		66	3.937	7 m.

**Motocicletas:**

Denominación Comercial	Contraseña de Homologación	Tipo	Variante	NIVEL SONORO		
				dB (A)	r.p.m.	Distancia
FORMULA 125	A-1115	FR2		79	3.750	50 cm.

**MARCA: KAWASAKI****Motocicletas:**

Denominación Comercial	Contraseña de Homologación	Tipo	Variante	NIVEL SONORO		
				dB (A)	r.p.m.	Distancia
GPZ 600 R	A-0203	ZX600A GPZ600R		77/8	7.875	7 m.
KLR 600	A-0205	KL600B KLR600		78/3	5.250	50 cm.

MARCA: **KAWASAKI**

## Motocicletas:

Denominación Comercial	Contraseña de Homologación	Tipo	Variante	NIVEL SONORO		
				dB (A)	r.p.m.	Distancia
GPZ 900 R	A-0206	ZX900A Ext.1	ZX900 A7 (I)	99	7.125	7 m.
GPZ 900 R	A-0206	ZX900A GPZ900R		85	7.125	7 m.
GPZ 1000 RX	A-0240	ZXT00A GPZ 1000RX		81'5	7.125	7 m.
KLR 650	A-0281	KL650A KLR650		86	3.250	50 cm.
GPX 750 R	A-0282	ZX750F GPX750R		93	5.250	50 cm.
ZX400 C	A-0288	ZX400C Ext.1	ZX400C4	89	5.750	50 cm.
Z400 F-11	A-0288	ZX400C	ZX400C1 ZX400C2 ZX400C3	96	5.750	50 cm.
GT 550	A-0308	KZ550G Ext.1		89	4.750	50 cm.
GT 550	A-0308	KZ550G	KZ550 G3 G4 G5	87	4.500	50 cm.
GPX 600 R	A-0317	ZX600C GPX600R	ZX600 C1, C2, C3	94	5.500	50 cm.
ZX 10	A-0328	ZXT00B ZX 10	B1, B2, B3	96	7.500	50 cm.
TENGAI	A-0359	KL650B Tengai	KL650 B1, B2, B3	94'5	5.250	50 cm.
ZXR 750	A-0366	ZX750H ZXR750	ZX750H 1, 2, 3	94	5.250	50 cm.
GPZ 500 S	A-0412	EX500A (GPZ 500S ) Ext.1	EX500A1 EX500A2 EX500A3 EX500D	88	4.900	50 cm.
GPZ 500 S	A-0412	EX500A (GPZ 500S)	EX500 A1, A2, A3	89	4.900	50 cm.
ZZR 600	A-0413	ZX600D ZZR600	ZX600D 1, 2, 3	93	5.750	50 cm.
EN 500	A-0414	EN500A EN500	EN500A 1, 2, 3	89	4.250	50 cm.

MARCA: **KAWASAKI**

## Motocicletas:

Denominación Comercial	Contraseña de Homologación	Tipo	Variante	NIVEL SONORO		
				dB (A)	r.p.m.	Distancia
EN 500	A-0414	EN500A EN500 Ext.1	EN500A1 EN500A2 EN500A3 EN500B	89	4.250	50 cm.
EN 500	A-0414	EN500A EN500 Ext.2	EN500A1 (I) EN500A2 (II) EN500A3 (III) EN500B (IV) EN500C (V)	86	3.750	50 cm.
ZZR 1100 ZX 1100 C	A-0415	ZXT10C (ZZR 1100)	ZXT10C 1, 2, 3	94	5.250	50 cm.
ZEPHYR 750	A-0446	ZR750C Zephyr 750		96	7.125	50 cm.
ZXR 750	A-0448	ZX750J ZXR750		90	5.250	50 cm.
ZXR 750 R	A-0449	ZX750K ZXR 750R		93	5.750	50 cm.
KLE 500	A-0450	LE500A KLE 500A		88	4.250	50 cm.
ZEPHYR	A-0480	ZR550B		97	7.500	50 cm.
ZEPHYR 92	A-0480	ZR550B Ext.1	ZR550B 92	93	5.000	50 cm.
ZEPHYR 1100	A-0494	ZRT10A ZR 1100A		91	4.000	50 cm.
ZXR 750	A-0511	ZX750L		90	5.500	50 cm.
ZZR 1100	A-0512	ZXT10D ZX 1100D		92	5.250	50 cm.
ZZR 1100	A-0512	ZXT10D ZX 1100D Ext.1	ZXT10D 95	94	5.250	50 cm.
ZZR 600	A-0522	ZX600E		91	5.750	50 cm.
ZZR 600	A-0522	ZX600E Ext.1	ZX600E 95	90	6.000	50 cm.
KLX 650	A-0523	LX650C KLX 650C		84	3.250	50 cm.
VN 750 TWIN	A-0539	VN750A		87	3.750	50 cm.
NINJA ZX 9R	A-0568	ZX900B		92	5.250	50 cm.
NINJA ZX 9R	A-0568	ZX900B Ext.2	ZX900B 95 ZX900B 96	89	5.250	50 cm.
NINJA ZX 9R	A-0568	ZX900B Ext.1	ZX900B 95	89	5.250	50 cm.
KLX 650	A-0569	LX650A		91	3.250	50 cm.

MARCA: **KAWASAKI**Motocicletas:

Denominación Comercial	Contraseña de Homologación	Tipo	Variante	NIVEL SONORO		
				dB (A)	r.p.m.	Distancia
VN 15	A-0578	VNT50A VN 1500C		92	3.225	50 cm.
VN 1500 CLASSIC	A-0578	VNT50 VNT50A Ext.1	VN1500D	93	3.525	50 cm.
GPZ 1100	A-1013	ZXT10E		91	4.750	50 cm.
KLR 650	A-1014	KL650C		86	3.500	50 cm.
NINJA ZR 6R	A-1015	ZX600F		96	6.250	50 cm.
VN 800	A-1024	VN800A		90	5.250	50 cm.
VN 800 CLASSIC	A-1024	VN800A Ext.1	VN800B	91	3.500	50 cm.
NINJA ZX 7R	A-1050	ZX750P		93	5.900	50 cm.
ER5	A-1080	ER500A	ER500A (A) ER500A (B)	88	4.500	50 cm.
KLX 300 A	A-1106	LX300A		96	3.500	50 cm.
ELIMINATOR	A-1125	BN125A	A	83	4.750	50 cm.
NINJA ZX 9R	A-1140	ZX900C	C1, C2, D1, D2	96	5.500	50 cm.
NINJA ZX 6R	A-1155	ZX600G	G1, G2, H1, H2	93 92 91 92	6.000 6.000 6.000	50 cm.
VN 1500 CLASSIC TOURER	A-1159	VNT 50G	G-H	93	3.525	50 cm.
ZZR 250	A-1161	EX250H	H	89	6.250	50 cm.
DRIFTER	e1*92/61*00008	VN800C	C	91	3.750	50 cm.
KLR 650	e1*92/61*00010	KL650C	C	86	3.500	50 cm.
ZR 7	e1*92/61*00023	ZR750F	F	87	3.750	50 cm.
ER 5	e1*92/61*00039	ER500A	C	87	4.000	50 cm.
NINJA ZX-9R	e1*92/61*00054	ZX900E	E-11A	91	5.150	50 cm.
ELIMINATOR	e1*92/61*00056	BN125A	A1	83	4.750	50 cm.
NINJA ZX-12R	e1*92/61*00065	ZXT20A	A-11A	96	5.250	50 cm.
VULCAN 500	e1*92/61*00073	EN500A	C1	85	3.500	50 cm.
KLE 500	e1*92/61*00074	LE500A	C1	84	3.750	50 cm.
ZZR 250	e1*92/61*00076	EX250H	H1	90	6.250	50 cm.
W 650	e4*92/61*0010	EJ650A	A	90	3.000	50 cm.
NINJA ZX6R	e4*92/61*0042	ZX600J	11A	90	3.000	50 cm.
VULCAN 1500 CLASSIC	e4*92/61*0063	VNT50N	N	95'4	3.525	50 cm.
ZRT 20A	e4*92/61*0106	ZRT20A		91	4.250	50 cm.
KDX 220	e9*92/61PS*B004	KD220		93	3.500	50 cm.

MARCA: **KYMCO**Ciclomotores:

Denominación Comercial	Contraseña de Homologación	Tipo	Variante	NIVEL SONORO		
				dB (A)	r.p.m.	Distancia
K12 / SCOUT 50	CI-1045	S*10 Ext.2	K12	68	4.875	7 m.
K 12	CI-1045	S*10 Ext.1	K12	68	4.875	7 m.
KB 50	CI-1045	S*10		68	4.875	7 m.
HEROISM 50	CI-1049	S*10(H) Ext.1		67	4.875	7 m.
HEROISM 50	CI-1049	S*10(H)		67	4.875	7 m.
CURIO / DIW / DTR	CI-1050	S*10(C) Ext.2	SA10AA SA10AL	66	5.062	7 m.
CURIO	CI-1050	S*10(C)		66	5.062	7 m.
CURIO / DIW	CI-1050	S*10(C)	SA10AA	66	5.062	7 m.
DJW / DJR / FEVER 50	CI-1050	S*10(C) Ext.3	SA10AA SA10AL	66	5.062	7 m.
DJW / DJR / FEVER 50	CI-1050	S*10(C) Ext.4	SA10AA SA10AL	66	5.062	7 m.
FILLY 50	CI-1106	SD	10/AC	70	5.887	7 m.
TOP BOY 50 On Road	CI-1110	SF	10/AF	84	5.250	7 m.
TOP BOY 50 Off Road	CI-1110	SF	10/AG	84	5.250	7 m.
DINK 50	CI-1135	SH10	10/AA, 10/BA	72	5.100	7 m.
SCOUT 50	e1*92/61*00080	SC10AS		78	3.500	50 cm.
PEOPLE 50	e4*2000/7*0013	B1	00	72	2.700	50 cm.
SUPER 9	e4*92/61*0074	S1	00-00	78	3.125	50 cm.
YUP 50	e4*92/61*0112	S6	00-00	76	3.250	50 cm.

Motocicletas:

Denominación Comercial	Contraseña de Homologación	Tipo	Variante	NIVEL SONORO		
				dB (A)	r.p.m.	Distancia
TOP HEROISM 125	A-1054	S*25(H) Ext.1		82	3.875	50 cm.
HEROISM 125	A-1054	S*25(H)		82	3.875	50 cm.
DINK 125	A-1112	SH	25/AA	81	4.000	50 cm.
DINK 125	A-1112	SH Ext.1	25/AA, 30/AA	79	4.000	50 cm.
DINK 150				81	3.875	
ZING 150	A-1113	RF	30/AA, 25/AA	86	4.250	50 cm.
ZING 125				82	4.500	
MOVIE 125	A-1120	SL	25/AA	83	3.750	50 cm.
TOP BOY 100	A-1177	SF20	AF/-, AG/-	82	3.200	50 cm.
BET WIN 125	e13*92/61*0025	S3	00/10	80	4.000	50 cm.
BET WIN 150	e13*92/61*0025	S3	00/00	81	3.750	50 cm.
MOVIE 125 XL	e4*2000/7*0125	S5	10	80	3.875	50 cm.
MOVIE 150 XL	e4*2000/7*0125	S5	00	85	3.750	50 cm.

**MARCA: KYMCO****Motocicletas:**

Denominación Comercial	Contraseña de Homologación	Tipo	Variante	NIVEL SONORO		
				dB (A)	r.p.m.	Distancia
GRAND DINK 250	e4*2000/7*0125	S4	10-00	82	3.750	50 cm.
BET WIN 250	e4*92/61*0092	S7		79	3.375	50 cm.

**MARCA: KTM****Motocicletas:**

Denominación Comercial	Contraseña de Homologación	Tipo	Variante	NIVEL SONORO		
				dB (A)	r.p.m.	Distancia
DUKE 620	A-1028	620 Variante I	DUKE620	93	3.125	50 cm.
GS 620	A-1028	620 Variante II	GS 620	93	3.125	50 cm.
125	A-1108	125LC2	B/A	89	3.900	50 cm.
125 ENDURO	A-1153	2T EGS	A/-,B/-, C/-,D/-	89	3.375	50 cm.
200 ENDURO				89	3.000	
250 ENDURO				89	3.375	
300 ENDURO				55	2.875	
640 LC4	A-1205	4T EGS	1C, 2C	91	3.375	50 cm.
				87	3.750	
640 LC 4	e1*92/61*00007	KTM 4T-EGS	Ca	88	3.375	50 cm.
640 LC 4	e1*92/61*00007	KTM 4T-EGS	Cb	89	3.750	50 cm.
640 ADVENTURE	e1*92/61*00007	KTM 4T-EGS	Da	88	3.375	50 cm.
640 ADVENTURE	e1*92/61*00007	KTM 4T-EGS	Db	89	3.750	50 cm.
640 LC4 Super Moto	e1*92/61*00007	KTM 4T-EGS	Ca,2	88	3.375	50 cm.
640 LC4 Super Moto	e1*92/61*00007	KTM 4T-EGS	Cb,2	89	3.750	50 cm.
640 Duke Color I	e1*92/61*00048	KTM Dk II	Aa	87	3.250	50 cm.
640 Duke Color I	e1*92/61*00048	KTM Dk ii	Ab	88	3.625	50 cm.
125 EXC	e1*92/61*00060	KTM 2T-EXC	A	78	2.750	50 cm.
200 EXC	e1*92/61*00060	KTM 2T-EXC	B	87	4.250	50 cm.
250 EXC	e1*92/61*00060	KTM 2T-EXC	C	82	3.250	50 cm.
300 EXC	e1*92/61*00060	KTM 2T-EXC	D	82	3.375	50 cm.
400 EXC	e1*92/61*00067/00	KTM 4T-EXC	A	88	3.375	50 cm.
520 EXC	e1*92/61*00067/00	KTM 4T-EXC	B	88	3.250	50 cm.

**MARCA: MALAGUTI****Ciclomotores:**

Denominación Comercial	Contraseña de Homologación	Tipo	Variante	NIVEL SONORO		
				dB (A)	r.p.m.	Distancia
PHANTOM F-12	CI-1051	ZJM4	ZJM40/D ZJM41	64	4.875	7 m.

**MARCA: MALAGUTI****Ciclomotores:**

Denominación Comercial	Contraseña de Homologación	Tipo	Variante	NIVEL SONORO		
				dB (A)	r.p.m.	Distancia
PHANTOM F-12	CI-1051	ZJM4. Ext. 1	ZJM40/D ZJM41	64	4.875	7 m.
F-10	CI-1062	ZJM 39/D		73	4.500	7 m.
CENTRO	CI-1072	ZJM42/D		73	6.600	7 m.
FIRE FOX F15	CI-1088	44		78'2	5.250	7 m.
YESTERDAY	CI-1126	45	00/00	73	4.500	7 m.

**MARCA: MBK****Ciclomotores:**

Denominación Comercial	Contraseña de Homologación	Tipo	Variante	NIVEL SONORO		
				dB (A)	r.p.m.	Distancia
MÁGNUM	CI-0065	512	512 Magnum	79	3.375	7 m.
TZR 50	CI-1070	4YV	I/iii	72	3.188	50 cm.
YN 50	CI-1076	5AD		78	3.100	50 cm.
YQ 50	CI-1097	5BR	I/i	73	5.250	7 m.
CW 50 RS	CI-1146	SA05	I/i	87	4.950	50 cm.
EW 50	CI-1162	SA09	I/i	85	4.875	50 cm.
EW 50	e13*92/61*0017*00	SA09	I/ii y iv	80	3.400	50 cm.
EW 50	e13*92/61*0017*03	SA09	I/vi	79	3.375	50 cm.
CW 50 RS	e13*92/61*0029*00	SA05	2	81	3.400	50 cm.
YQ 50	e13*92/61*0036*00	SA14	I/ii	77	3.375	50 cm.
YN 50	e9*92/61*0042*00	SA15	I/ii	80	3.250	50 cm.

**Motocicletas:**

Denominación Comercial	Contraseña de Homologación	Tipo	Variante	NIVEL SONORO		
				dB (A)	r.p.m.	Distancia
YP 125	e9*92/61*0046	SE06	I/ii y iv	89	4.375	50 cm.
YP 150	e9*92/61*0047	SG08	I/ii	81	4.125	50 cm.

**MARCA: MONTESA****Motocicletas:**

Denominación Comercial	Contraseña de Homologación	Tipo	Variante	NIVEL SONORO		
				dB (A)	r.p.m.	Distancia
COTA 335	A-0271	61 M. COTA 335		90	2.062	50 cm.
COTA 125	A-0272	28 M. COTA 125		85	3.567	50 cm.
COTA 304	A-0273	39M. COTA 304		85	2.437	50 cm.
COTA 307	A-0307	39 MA. COTA 307		89	3.750	50 cm.

**MARCA: MONTESA****Motocicletas:**

Denominación Comercial	Contraseña de Homologación	Tipo	Variante	NIVEL SONORO		
				dB (A)	r.p.m.	Distancia
COTA 309	A-0356	39 M T89.	COTA 309	93	3.750	50 cm.
COTA 310	A-0394	NT01.	COTA 310	93	3.375	50 cm.
COTA 310 T	A-0394	NT01.	COTA 310 COTA 310 Ext.1 TRAIL	92	3.375	50 cm.
COTA 311	A-0458	NT02.	COTA 311	91'3	3.375	50 cm.
COTA 314	A-0561	NT03		88	3.750	50 cm.
COTA 315	A-1091	MT03		93	3.560	50 cm.
COTA 315 R	A-1091	MT03		93	3.750	50 cm.

**MARCA: MOTO GUZZI****Motocicletas:**

Denominación Comercial	Contraseña de Homologación	Tipo	Variante	NIVEL SONORO		
				dB (A)	r.p.m.	Distancia
V 75	A-0245	V75		95	4.950	50 cm.
NEVADA 750	A-0472	LF Nevada	750	88	3.100	50 cm.
CALIFORNIA 1100 / 1100i	A-0473	VYExt.1	VY VY-C KD, KC	93	3.200	50 cm.
CALIFORNIA EVOLUCIONE	A-0473	VYExt.2	KD, KC KD/B2	93	3.200	50 cm.
CALIFORNIA III	A-0473	VY California III	VY-C*	95		50 cm.
SPORT 1100 E	A-1100	K	KF, KK, KL	90	3.900	50 cm.
VIO CENTAURO				91	4.100	50 cm.
DAYTONA RS				91	4.200	50 cm.
CALIFORNIA	e11*92/61*00033	KD		90	3.200	50 cm.
NEVADA 750	e3*92/61*0010	LK		88	3.300	50 cm.
V11 Sport/Le Mans	e3*92/61*0075	KS		89	3.900	50 cm.

**MARCA: MOTOR HISPANIA****Ciclomotores:**

Denominación Comercial	Contraseña de Homologación	Tipo	Variante	NIVEL SONORO		
				dB (A)	r.p.m.	Distancia
MH STYLE	CI-0120	MST	Agua	74	5.625	7 m.
KR	CI-1023	KR		76	6.187	7 m.
MINICROSS	CI-1065	MHMC		75	5.625	7 m.
NH FURIAZ	CI-1079	FU01		69	4.500	7 m.
RACING RX	e9*92/61*0038	DR01		78	3.250	7 m.

**MARCA: MuZ****Motocicletas:**

Denominación Comercial	Contraseña de Homologación	Tipo	Variante	NIVEL SONORO		
				dB (A)	r.p.m.	Distancia
SKORPION	A-1026	660	TE2, SE2	75	6.418	50 cm.
T-REX 125	A-1200	CP125		77	3.375	50 cm.

**MARCA: MV AGUSTA****Motocicletas:**

Denominación Comercial	Contraseña de Homologación	Tipo	Variante	NIVEL SONORO		
				dB (A)	r.p.m.	Distancia
F4 750 S	e3*92/61*0024*00	F4	01/AA 01/AB 01/BA 01/BB	96	6.250	50 cm.

**MARCA: PGO****Ciclomotores:**

Denominación Comercial	Contraseña de Homologación	Tipo	Variante	NIVEL SONORO		
				dB (A)	r.p.m.	Distancia
SPORT COMET 50	CI-1007	S 50/1		73'7	4.500	7 m.
GALAXY 50	CI-1019	G 50		74	4.125	7 m.
BIG MAX SPORT	CI-1025	PS 50	PS50, PS50 SPORT	75	4.688	7 m.
BIG MAX SPORT	CI-1025	PS 50		75	4.688	7 m.
BIG MAX 50	CI-1025	PS 50 Ext.2	PS50 PS50 SPORT PT50, PT50 SPORT	75	4.688	7 m.

**Motocicletas:**

Denominación Comercial	Contraseña de Homologación	Tipo	Variante	NIVEL SONORO		
				dB (A)	r.p.m.	Distancia
BIG MAX 90	A-1055	PS90		76'2	3.925	7 m.

**MARCA: PEUGEOT****Ciclomotores:**

Denominación Comercial	Contraseña de Homologación	Tipo	Variante	NIVEL SONORO		
				dB (A)	r.p.m.	Distancia
FOX	CI-0114	T057		73	4.125	7 m.
ZENITH	CI-0115	FE 052		75	4.350	7 m.
BUXY/SPEEDAKE	CI-1000	FE 053	(I) Buxy, (II) Speed	75	4.350	7 m.
BUXY/SPEEDAKE	CI-1000	FE 053	Speedake	75	4.350	7 m.

**MARCA: PEUGEOT****Ciclomotores:**

Denominación Comercial	Contraseña de Homologación	Tipo	Variante	NIVEL SONORO		
				dB (A)	r.p.m.	Distancia
SV 50	CI-1048	F 052 (95)	SV50, SV50L	64	3.750	7 m.
SV50	CI-1048	F 052 (95)		64	3.750	7 m.
SQUAB	CI-1055	S1A	00/0	78	3.500	7 m.
TREKKER	CI-1055	S1A	00/A	78	3.500	7 m.
TREKKER ROAD	CI-1055	S1A	00/B	83	4.875	7 m.
SPEEDFIGHT	CI-1081	S1B	S1B.A, S1B.B.	83	6500	7 m.
SCOOT'ELEC	CI-1093	E1A		52		7 m.
ELYSEO 50	CI-1133	G1A	A0/0	70	5.250	7 m.
VIVACITY 50	CI-1152	S1C	00/A	73	5.250	7 m.
LOOXOR 50	E2*92/61*0014	B1	AA/AA	77	3.250	50 cm.

**Motocicletas:**

Denominación Comercial	Contraseña de Homologación	Tipo	Variante	NIVEL SONORO		
				dB (A)	r.p.m.	Distancia
SC 80 L / SX 80	A-0230	SC80L		90		50 cm.
SC 75 L	A-0301	F071		80	4.500	50 cm.
SV 100	A-0454	F121	SV125 SV125L SV100/C	93	3.800	50 cm.
SV 125	A-0454	F121		90	4.875	50 cm.
SV 125 L	A-0454	F121	SV125, SV125L	85	3.250	50 cm.
SV 92	A-0499	F082	SV80L	84	3.250	50 cm.
SV 75	A-0530	F072		85	3.600	50 cm.
SPEEDFIGHT 100	A-1119	S2A	B	87	3.750	50 cm.
TREKKER 100	A-1119	S2A	A	87	3.750	50 cm.
ELYSEO 100	A-1154	G2A	A	87	3.550	50 cm.
VIVACITY 100	A-1221	S2AC		85	3.500	50 cm.
ELYSEO 125	e2*92/61*0005	G2A	B	84	4.375	50 cm.
ELYSEO 150	e2*92/61*0005	G2A	C/00	85	4.225	50 cm.
LOOXOR 100	e2*92/61*0015	B2	AB/AA	86	3.625	50 cm.

**MARCA: PIAGGIO****Ciclomotores:**

Denominación Comercial	Contraseña de Homologación	Tipo	Variante	NIVEL SONORO		
				dB (A)	r.p.m.	Distancia
VESPINO SC/SCA AL/AL e Elestart F9 / F9	CI-0004	SCA		72	5.700	7 m.

**MARCA: PIAGGIO****Ciclomotores:**

Denominación Comercial	Contraseña de Homologación	Tipo	Variante	NIVEL SONORO		
				dB (A)	r.p.m.	Distancia
VALE Especial Standard	CI-0005	Standard		80	3.525	7 m.
PUCH Condor / PUCH TZ	CI-0053	120C	----	69	6.300	7 m.
VESPA DELTA	CI-0059	123-C	----	69	5.800	7 m.
F9 y F9e / NL	CI-0088	F9	I II	72	4.500	7 m.
VESPINO NLX-P			III			
ZIP	CI-0089	SSL2-T	----	69	6.000	7 m.
FREE	CI-0101	FCS1-T	00	80	6.200	7 m.
FREE 50	CI-0101	FCS2-T	1	86	4.125	50 cm.
TYPHOON	CI-0110	TEC1-T	----	81	6.600	7 m.
TYPHOON-50			1			
TYPHOON-50 MY			2			
ZIP SPORT	CI-0111	SSP1-T	----	80	6.200	50 cm.
PIAGGIO-STORM	CI-1014	TEC1-T	----	68	6.000	7 m.
NRG	CI-1031	SAL1-T	I: NRG II: NTT	72	4.687	7 m.
NTT						
VESPINO CPE	CI-1038	C02	----	68	4.050	7 m.
BIMODAL	CI-1042	BMZ1-T	----	72	4.687	7 m.
SFERA 50	CI-1043	C01	00	69	4.800	7 m.
NRG-MY	CI-1067	C04	I	68	4.350	7 m.
ZIP BASE-MY	CI-1068	C06	----	69	4.500	7 m.
ZIP SPORT MY	CI-1069	C07	1	70	4.500	7 m.
ZIP AGUA	CI-1075	C11	----	70	4.500	7 m.
VESPA 50 Inyección	CI-1099	C12	3	91	4.685	50 cm.
LIBERTY	CI-1100	C15	----	83	5.060	7 m.
VESPA 50 Carburación	CI-1101	C16	3	83	4.690	50 cm.
MC2-98	CI-1125	C18	I	81	2.875	7 m.
VESPINO F.18	CI-1137	C14-E	1	72	4.875	7 m.
NRG F.L. AGUA	CI-1158	C22	100	85'5	4.875	50 cm.
NRG F.L. AIRE	CI-1159	C21	100	86	5.250	50 cm.
BRAVO 50	CI-1161	C20	100/101	78	4.000	50 cm.
VESPINO F18 / NL	CI-1163	C23	000/001	76	4.875	50 cm.
TYPHOON 50 RST	CI-1166	C19	300	84	4.500	50 cm.
NRG H20 MC3	e11*92/61*00039*00	C32	100	84	3.625	50 cm.
NSP 50 2T AIRE	e3*92/61*0020*03	C25	100	80	3.250	50 cm.
NSP 50 4T	e3*92/61*0020*04	C25	200	78	3.375	50 cm.
ZIP SP KAT	e3*92/61*0020*05	C25	300	78	3.500	50 cm.
ZIP SP KAT	e3*92/61*0020*06	C25	600	81	3.625	50 cm.
LIBERTY ET4 50	e3*92/61*0035*00	C28	200	88	3.625	50 cm.



## MARCA: PIAGGIO

## Ciclomotores:

Denominación Comercial	Contraseña de Homologación	Tipo	Variante	NIVEL SONORO		
				dB (A)	r.p.m.	Distancia
VESPA ET4 50	e3*92/61*0041*00	C26	100	88	3.625	50 cm.
NRG F.L. AIRE KAT	e3*92/61*0051*00	C21	510	81	3.250	50 cm.
VESPINO	e9*92/61*0024*00	C23	300/002	76	4.875	50 cm.

## Motocicletas:

Denominación Comercial	Contraseña de Homologación	Tipo	Variante	NIVEL SONORO		
				dB (A)	r.p.m.	Distancia
VESPA 75	A-0045	75 c.c.	-----	75	4.125	7 m
VESPA 125	A-0046	125 c.c.	-----	83	4.575	7 m
VESPA 200	A-0047	200 c.c.	-----	76	4.200	7 m
VESPA 150	A-0048	150 c.c.	-----	78	4.200	7 m
P 125 X	A-0112	P 125 X	I	90	3.125	50 cm.
PX 125			II			
VESPA P 125 X, 125 CL	A-0112	P 125 X	-----	82	3.975	50 cm.
VESPA PK 75 S	A-0137	PK 75 S	PK 75 S	82	4.125	50 cm.
VESPA PK 75 S Elestart			ELESTART			
PK 125 S	A-0138	PK 125 S	I	86	2.750	50 cm.
PK 125 S ELESTART			II			
PK 125 XL			III			
PK 125 XL ELESTART			IV			
VESPA PK 125 S	A-0138	PK 125 S	I	86	2.750	50 cm.
VESPA PK 125 S Elestart			II			
VESPAPK 125 XL			III			
VESPA PK 125 XL Elestart			IV			
VESPA PK 75 XL	A-0257	PK 75 XL	-----	96	5.325	50 cm.
VESPA PK 75 XL Elestart						
PK 75 XL ELESTART						
VESPA PX 125 T5	A-0258	PX 125 T5	I	96	5.025	50 cm.
VESPA PX 125 T5 Elestart			II			
TX 200	A-0316	TX 200	I	90	2.825	50 cm.
TX 200			II			
PX 200 E			III			
VESPA TX 200	A-0316	TX 200	I	90	2.825	50 cm.
VESPA TX 200			II			
VESPA PX 200 E			III			
VESPA XL 125	A-0338	XL 125	-----	93	4.650	50 cm.
Plurimatic		Plurimatic				
VESPA XL 125			XL 125			
Plurimatic Elestart			Plurimatic Elestart			



## MARCA: PIAGGIO

## Motocicletas:

Denominación Comercial	Contraseña de Homologación	Tipo	Variante	NIVEL SONORO		
				dB (A)	r.p.m.	Distancia
VESPA COSA 125	A-0417	COSA 125	-----	87	3.000	50 cm.
VESPA COSA 200	A-0418	COSA 200	-----	88	3.000	50 cm.
SFERA 80	A-0471	NS8-IT (Sfera 80)	-----	83	4.800	50 cm.
VESPA SFERA 80	A-0471	NS8-IT Sfera 80	-----	83	4.800	50 cm.
SKIPPER-125	A-0548	CSMIT	-----	84	5.400	50 cm.
SKIPPER-150	A-0567	CVM1T	-----	86	5.600	50 cm.
HEXAGON 150	A-1004	EXV1T	-----	87	3.875	50 cm.
TYPHOON 80	A-1016	TE81T	-----	85	3.750	50 cm.
HEXAGON 125	A-1032	EXS1T	-----	86	3.750	50 cm.
SFERA 125	A-1035	M01	1	82	3.800	50 cm.
TYPHOON 125	A-1041	M02	1	85	3.800	50 cm.
VESPÀ 125 - 4T	A-1079	M04	-----	84	3.850	50 cm.
HEXAGON 180 RST	A-1132	M06	-----	91	4.125	50 cm.
HEXAGON 125 RST	A-1133	M05	-----	91	3.750	50 cm.
RUNNER 125	A-1134	M07	1	76	3.500	50 cm.
RUNNER 180	A-1135	M08	1	89	4.000	50 cm.
SKIPPER RST 125	A-1174	M12	I	86	3.500	50 cm.
SKIPPER LXT 150	A-1175	M13	I	86	3.625	50 cm.
HEXAGON 250 GT	A-1176	M14	I	86	3.250	50 cm.
LIBERTY 125 4T	A-1183	M11	1	83	3.750	50 cm.
HEXAGON 125 4T	A-1208	M15	1	83	3.750	50 cm.
SKIPPER 80	A-1217	M16	1	86	3.750	50 cm.
VESPA 200	A-1244	M18	100	91	3.125	50 cm.
VESPA 150	e11*92/61*00002*03	M19	100	82	3.750	50 cm.
VESPA 150	e11*92/61*00002*03	M19	200	86	4.000	50 cm.
SKIPPER 150 4T	e11*92/61*00018*03	M21	100	84	3.750	50 cm.
SKIPPER 125 4T	e11*92/61*00018*03	M21	200	84	4.000	50 cm.
X9 250	e11*92/61*00022*01	M23	100	83	3.500	50 cm.
X9 125	e11*92/61*00022*03	M23	200	89	4.875	50 cm.
X9 180	e11*92/61*00022*04	M23	300	86	4.375	50 cm.
X9 500	e11*92/61*00038*01	M27	101	91	3.625	50 cm.
HEXAGON 125 4T/4V	e3*92/61*0013*02	M20	100	89	5.000	50 cm.
HEXAGON 180 4T/4V	e3*92/61*0013*03	M20	200	85	4.250	50 cm.
HEXAGON 125 4T/4V	e3*92/61*0013*04	M20	101	88	5.000	50 cm.
HEXAGON 180 4T/4V	e3*92/61*0013*05	M20	201	86	4.250	50 cm.
LIBERTY 125 4T	e3*92/61*0015*01	M22	200	84	4.000	50 cm.
LIBERTY 150 4T	e3*92/61*0015*02	M22	100	86	3.750	50 cm.
LIBERTY 150 4T	e3*92/61*0015*05	M22	100	86	3.750	50 cm.
LIBERTY 125 4T	e3*92/61*0015*06	M22	200	84	4.000	50 cm.

**MARCA: PIAGGIO**Motocicletas:

Denominación Comercial	Contraseña de Homologación	Tipo	Variante	NIVEL SONORO		
				dB (A)	r.p.m.	Distancia
ZIP 125 4T	e3*92/61*0039*02	M25	100	86	4.000	50 cm.
ZIP 125 4T	e3*92/61*0039*03	M25	100	86	4.000	50 cm.
RUNNER VXR 180	e3*92/61*0043*01	M24	200	87	4.375	50 cm.
RUNNER VX 125	e3*92/61*0043*02	M24	100	90	4.875	50 cm.
RUNNER VX 125	e3*92/61*0043*04	M24	100	90	4.875	50 cm.
RUNNER VXR 180	e3*92/61*0043*05	M24	200	87	4.375	50 cm.

**MARCA: RIEJU**Ciclomotores:

Denominación Comercial	Contraseña de Homologación	Tipo	Variante	NIVEL SONORO		
				dB (A)	r.p.m.	Distancia
DRAC 50 L						
DRAC 50 A	CI-0063	50	DRAC50A	68	4.125	7 m.
RS1 L/D	CI-0097	RS1 L/D		74	4.125	7 m.
DRAC 50 D/L	CI-0098	DRAC 50 D/L		67	4.025	7 m.
WINDY	CI-0102	WINDY		69	5.062	7 m.
RR	CI-0112	RR		67	5.062	7 m.
RR 50 AM	CI-1009	RR 94		67	5.062	7 m.
RR 50 AM6	CI-1009	RR 94	RR50 AM6	67	5.062	7 m.
SUPER MOTARD	CI-1009	RR 94 Ext.3	RR50 AM6	67	5.062	7 m.
RR 50 AM6	CI-1009	RR 94 Ext.1	RR50 AM6	67	5.062	7 m.
SPIKE	CI-1009	RR		87	3.375	50 cm.
CASTROL	CI-1009	RR		87	3.375	50 cm.
RR	CI-1009	RR		87	3.375	50 cm.
DRAC 50 AM	CI-1010	DRAC		67	5.062	7 m.
DRAC 50 AM6	CI-1010	DRAC Ext.1		67	5.062	7 m.
RS1	CI-1022	RS1 94		75	5.500	7 m.
RS1	CI-1022	RS1 94 Ext.1		76	4.125	7 m.
FIRST	CI-1041	SF		69	4.875	7 m.
FIRST	CI-1041	SF Ext.1	SF-W	69	4.875	7 m.
FIRST	CI-1041	SF Ext.2	SF-W	69	4.875	7 m.
CROSSER	CI-1063	ZJM43		73	4.500	7 m.
CROSSER	CI-1063	ZJM43 Ext.1		73	4.500	7 m.
RSE	CI-1114	RSE		80	3.562	50 cm.
RR	e9*92/61*0039	RR	1-0, 1-1 3-0, 4-0	85	3.000	50 cm.
RSE	e9*92/61*0040	RSE	0	88	2.875	50 cm.
MRX	e9*92/61*0074	MRX	100, 300	84	3.000	50 cm.

**MARCA: RIEJU**Motocicletas:

Denominación Comercial	Contraseña de Homologación	Tipo	Variante	NIVEL SONORO		
				dB (A)	r.p.m.	Distancia
MR 80	A-0189	MR80 Ext.1	Nuevo silencioso y freno disco Del. Var. MR80-1	82	6.375	50 cm.
MR 80	A-0189	MR74		82	6.375	50 cm.
RST 80	A-0331	ZJM 21/4		81'5	6.375	50 cm.
RST 80	A-0331	ZJM 21/4 Ext.1	1RST80	81'5	6.375	50 cm.

**MARCA: SHERCO**Motocicletas:

Denominación Comercial	Contraseña de Homologación	Tipo	Variante	NIVEL SONORO		
				dB (A)	r.p.m.	Distancia
SHERCO 125	A-1228	S1	12TR	86	3.000	50 cm.
SHERCO 250	A-1228	S1	25TR	86	3.375	50 cm.
SHERCO 290	A-1228	S1	29TR	85	2.750	50 cm.

**MARCA: SUZUKI**Ciclomotores:

Denominación Comercial	Contraseña de Homologación	Tipo	Variante	NIVEL SONORO		
				dB (A)	r.p.m.	Distancia
AH 50 ADDRESS	CI-1015	CA1GA		64	4.125	7 m.
DR 50	CI-1017	NA11A		75	3.750	7 m.
MC50	CI-1017	NA11C		75	3.750	7 m.
AP 50/RF	CI-1021	CA1JA		75	3.000	7 m.
RMX 50	CI-1047	SA12A		80	3.750	50 cm.
NM50/D	CI-1057	FA15A		73	4.500	7 m.
AY50/W/WR	CI-1092	AA		64	4.875	7 m.
TR50	CI-1113	AH		64	5.025	7 m.
UX50W	CI-1150	AT		64	4.500	7 m.
UF50 / UF 50 Z	e9*92/61*0023	BA		83	3.000	50 cm.

Motocicletas:

Denominación Comercial	Contraseña de Homologación	Tipo	Variante	NIVEL SONORO		
				dB (A)	r.p.m.	Distancia
GSX550ES	A-0178	GN71D		81	7.500	7 m.



## MARCA: SUZUKI

## Motocicletas:

Denominación Comercial	Contraseña de Homologación	Tipo	Variante	NIVEL SONORO		
				dB (A)	r.p.m.	Distancia
GR650	A-0179	GP51A		79,5	5.430	7 m.
GSX-750ES	A-0180	GR72A		84,5	7.125	7 m.
GSX-R750	A-0195	GR75A		83,5	7.875	7 m.
GSX 400 E	A-0196	GS40X		81,3	6.750	7 m.
DR 600 S/RH/R	A-0241	SN41A	DR600S/RH/R	80	5.050	7 m.
GSX-R1100	A-0242	GU74B		95	4.750	50 cm.
RG 125	A-0246	NF12B		76'3	7.025	7 m.
TS 125 X	A-0264	SF13A		76	6.000	7 m.
GSX 1100 F	A-0295	GV72BExt.1		94	4.750	50 cm.
GSX 1100 F	A-0295	GV72B		99	4.750	50 cm.
DR 750 S	A-0309	SR41A		95	4.950	50 cm.
GSX 600 F	A-0310	GN72A		103	8.250	50 cm.
GSX R 750	A-0311	GR77A		100	7.875	50 cm.
GS 450 E/S	A-0312	GL51C	GS450E/ S	95	6.750	50 cm.
GSX R 1100 L/M	A-0352	GV73B	GSX R1100/L/M	97	7.125	50 cm.
		Ext.1				
GSX 750 F	A-0353	GR78A		94	5.200	50 cm.
		Ext. 1				
GSX 750 F	A-0353	GR78A		96	7.800	50 cm.
GS 500 E/EU	A-0355	GM51A	GS500E	93	6.900	50 cm.
GS 500 E/EU	A-0355	GM51A Ext.1	GS500E (94)	88	4.500	50 cm.
GS 500 E/EU	A-0355	GM51A Ext.2	GS500EU	88	3.900	50 cm.
TS 125 R	A-0372	SF15A		96	7.350	50 cm.
GN 250	A-0388	NJ41A		88	4.000	50 cm.
DR 800	A-0403	SR42A Ext.1	SR43A	87	3.300	50 cm.
DR 800	A-0403	SR42A		89	3.500	50 cm.
GSX R750	A-0404	GR7AA		93	5.500	50 cm.
DR 650 R / RS	A-0405	SP41A DR650R	SP42A	94/93	3.400	50 cm.
		DR650RS				
GSF 400 BANDIT	A-0455	GK75A Ext.1	(93)	88	5.500	50 cm.
GSF 400 BANDIT	A-0455	GK75A		89	5.300	50 cm.
VS 750 GLP	A-0456	VR51A		92	3.750	50 cm.
DR 650 RSE	A-0457	SP43A		91	3.400	50 cm.
GSX R 750 W	A-0481	GR7BA Ext.1	(94)	95	5.750	50 cm.
GSX R 750 W	A-0481	GR7BA		98	5.750	50 cm.
VS 800GL/GLP	A-0482	VS52A Ext.2	VS800GL	88	3.250	50 cm.
VS 800GL/GLP	A-0482	VS52A	VS800GLP	95	3.500	50 cm.
AH 75	A-0493	CC13A		80	3.500	50 cm.
DR 650 R	A-0496	SP44	SP44A	91	3.400	50 cm.



## MARCA: SUZUKI

## Motocicletas:

Denominación Comercial	Contraseña de Homologación	Tipo	Variante	NIVEL SONORO		
				dB (A)	r.p.m.	Distancia
LS 650	A-0524	NP41A		83	4.050	50 cm.
RF 600 R	A-0531	GN76A		91	5.750	50 cm.
GSX R1100 W	A-0532	GU75B		93	5.000	50 cm.
RGV 250	A-0537	VJ21A		96	5.300	50 cm.
AH 100 ADDRESS	A-0540	CE12A		76	3.250	50 cm.
RGV 250	A-0558	VJ22A		98	7.333	50 cm.
RF 900 R	A-0565	GT73A		93	5.000	50 cm.
DR 650 RE	A-0566	SP45A		90	3.400	50 cm.
AN 125	A-1008	CF42A		79	3.750	50 cm.
VS 600 GL	A-1021	VN51A		91	3.700	50 cm.
GSF 600/S/R/SR	A-1023	GN77A Ext.2	GSF600R/SR	92	4.875	50 cm.
GSF 600/S/R/SR	A-1023	GN77A	GSF600/S	90	5.250	50 cm.
DR 650 SE	A-1047	SP46A		82	3.200	50 cm.
GSX R 750	A-1052	GR7DA. Ext.1	(98)	95	6.150	50 cm.
GSX R 750	A-1052	GR7DA.		94	6.000	50 cm.
GSF 1200/S/SA	A-1067	GV75A		91	4.250	50 cm.
TL 1000 S	A-1086	AG		91	4.250	50 cm.
XF 650	A-1087	AC		86	3.500	50 cm.
GSX R 600	A-1088	AD Ext.1	(98)	93	5.900	50 cm.
GSX R 600	A-1088	AD		94	6.000	50 cm.
TU 250X	A-1089	AB		88	4.000	50 cm.
VZ 800	A-1090	AF		84	3.250	50 cm.
DR 125	A-1138	SF44A		81	4.900	50 cm.
AN 150	A-1141	CG41A		80	3.650	50 cm.
GSX 750	A-1142	AE		90	4.750	50 cm.
GSX 600 F	A-1147	AJ Ext.1	R	88	5.000	50 cm.
SX 600 F	A-1147	AJ		90	5.250	50 cm.
GSX 750 F	A-1148	AK		94	5.250	50 cm.
TL 1000 R	A-1149	AM		92	4.750	50 cm.
VL 1500	A-1150	AL		93	3.600	50 cm.
GZ 125	A-1179	AP		87	4.500	50 cm.
AN 250	A-1180	AN		89	3.500	50 cm.
GZ 250	A-1190	AR		93	4.000	50 cm.
DR 350 SE	A-1195	SK42A		82	3.800	50 cm.
AN 400	A-1213	AU		91	4.000	50 cm.
TU 125 XT	A-1214	AZ		82	4.500	50 cm.
SV 650 /S	A-1215	AV Ext.1	R	87	4.500	50 cm.
SV 650 /S	A-1215	AV		89	4.500	50 cm.
UC 125	A-1219	AK		85	4.750	50 cm.



## MARCA: SUZUKI

## Motocicletas:

Denominación Comercial	Contraseña de Homologación	Tipo	Variante	NIVEL SONORO		
				dB (A)	r.p.m.	Distancia
UC 150	A-1220	AY		86	4.750	50 cm.
GS 125 S	A-1224	AW		83	4.800	50 cm.
GSX1200FS	A-1239	A3		90	4 250	50 cm.
VL250	A-1240	A5		90	4 250	50 cm.
VL125	A-1241	A4		90	5 250	50 cm.
VL 1500	e4*92/61*00099	WVAL		94	3.600	50 cm.
GSX1300R	e4*92/61*0012	WVA1	A11112	95	4 900	50 cm.
GSX1300R	e4*92/61*0012	WVA1	A11112	95	4 250	50 cm.
GSX1300R	e4*92/61*0012	WVA1	A13112	90	4 900	50 cm.
GSX1300R	e4*92/61*0012	WVA1	A13112	90	4 250	50 cm.
UG 110	e4*92/61*0049	WVA7		83	3.250	50 cm.
GSF 600 F	e4*92/61*0060	WVA8	(1)	88	5.250	50 cm.
GSF 600	e4*92/61*0060	WVA8	(2)	88	5.250	50 cm.
GSF 600 SU	e4*92/61*0060	WVA8	(3)	89	4.750	50 cm.
GSF 600 U	e4*92/61*0060	WVA8	(4)	89	4.750	50 cm.
DR Z 400 S	e4*92/61*0066	WVBC		87	3.800	50 cm.
GSX R 750	e4*92/61*0068	WVBD		95	6.250	50 cm.
GSF 1200 S	e4*92/61*0086	WVA9		91	4.250	50 cm.
AN 250	e4*92/61*0098	WVAN		92	3.500	50 cm.
AN 400	e4*92/61*0099	WVAU		91	4.000	50 cm.
GSX R 600	e4*92/61*0100	WVBG		94	6.400	50 cm.
GS 500	e4*92/61*0105	WVBK	BK1111	88	4.500	50 cm.
GS 500 H	e4*92/61*0105	WVBK	BK2111	90	4.600	50 cm.
GS 500 U	e4*92/61*0105	WVBK	BK3111	86	3.600	50 cm.
GS 500 HU	e4*92/61*0105	WVBK	BK4111	89	4.250	50 cm.
GSX R 1000	e4*92/61*0108	WVBL	BL1112	79	5.400	50 cm.
GSX R 1000 U1	e4*92/61*0108	WVBL	BL2112	79	5.000	50 cm.
GSX R 1000 U2	e4*92/61*0108	WVBL	BL3112	79	5.000	50 cm.
VL 800	e4*92/61*0109	WVBM		90	3.000	50 cm.
UE 125 CT	e4*92/61*0115	WVBH		80	3.750	50 cm.
GSX 1400	e4*92/61*0116	WVBN	BN1111	88	3.400	50 cm.
GSX 1400	e4*92/61*0116	WVBN	BN1112	88	3.400	50 cm.
GSX 1400 U	e4*92/61*0116	WVBN	BN2111	88	3.250	50 cm.
UE 150 CT	e4*92/61*0117	WVBJ		83	3.650	50 cm.



## MARCA: TRIUMPH

## Motocicletas:

Denominación Comercial	Contraseña de Homologación	Tipo	Variante	NIVEL SONORO		
				dB (A)	r.p.m.	Distancia
TROPHY 900	A-0501	T309 Ext.1	TC336	92	4.750	50 cm.
TRIDENT 900			TC338			
TRIDENT 900 SPRINT			TC362			
DAYTONA 900			TC357			
TIGER 900	A-0501	T309 Ext.1	TC430	88	4.750	50 cm.
TROPHY 900	A-0501	T309 Ext.3	TC336	93	4.500	50 cm.
TRIDENT 900			TC338			
SPRINT 900	A-0501	T309 Ext.3	TC362	92	4.100	50 cm.
TIGER 900	A-0501	T309 Ext.3	TC430	88	4.520	50 cm.
SPRINT TOURER EXE.	A-0501	T309 Ext.3	T309RG	92	4.700	50 cm.
SPRINT SPORT			T309RF			
TROPHY 900	A-0501	T309 Ext.2	TC336	93	4.500	50 cm.
TRIDENT 900			TC338			
DAYTONA 900			TC357			
SPRINT 900	A-0501	T309 Ext.2	TC362	92	4.500	50 cm.
SPEED TRIPLE			TC301			
TIGER 900	A-0501	T309 Ext.2	TC430	88	4.500	50 cm.
DAYTONA SUPER III	A-0501	T309 Ext.2	TC310	93	4.750	50 cm.
TROPHY 900	A-0501	T309	TC336	92	4.750	50 cm.
TRIDENT 900			TC338			
TROPHY 900	A-0501	T309 Ext.4	TC336	97	4.700	50 cm.
DAYTONA 1000	A-0502	T310	TC344	94	5.000	50 cm.
TRIDENT 750	A-0503	T375 Ext.1	TC333	93/90	5.000/4.875	50 cm.
DAYTONA 750	A-0503	T375	TC330	93	5.000	50 cm.
TRIDENT 750	A-0503	T375	TC333	91	4.875	50 cm.
TROPHY 1200	A-0504	T312 Ext.1	TC340	92	4.500	50 cm.
DAYTONA 1200	A-0504	T312 Ext.1	TC354	94	4.500	50 cm.
TROPHY 1200	A-0504	T312	TC345	92	4.500	50 cm.
DAYTONA 1200	A-0504	T312 Ext.2	TC354	94	4.780	50 cm.
TROPHY 1200	A-0504	T312 Ext.2	TC345	91	4.500	50 cm.
THUNDERBIRD	A-1022	T309RT	T309RT	93	4.125	50 cm.
THUNDERBIRD	A-1022	T309RT Ext.1	T309RT	92	4.000	50 cm.
ADVENTURER	A-1022	T309RT Ext.1	T309RC	91	4.000	50 cm.
THUNDERBIRD	A-1022	T309RT Ext.2	T309RT	91	4.000	50 cm.
ADVENTURER			T309RC			
THUNDERBIRD SPORT	A-1022	T309RT Ext.2	R309RD	96	4.250	50 cm.
LEGEND TT	A-1022	T309RT Ext.2	R309RL	91	4.000	50 cm.
LEGEND TT	A-1022	T309RT Ext.2	R309RL-R	89	3.250	50 cm.
SPEED TRIPLE	A-1085	T5	T509RP	90	4.600	50 cm.

MARCA: **TRIUMPH**Motocicletas:

Denominación Comercial	Contraseña de Homologación	Tipo	Variante	NIVEL SONORO		
				dB (A)	r.p.m.	Distancia
DAYTONA	A-1085	T5	T509SP	93	4.900	50 cm.
SPRINT ST	A-1223	T6	95ABT, 95ABT-R	90	4.750	50 cm.
TIGER	A-1233	T7	09ENT	90	4.100	50 cm.
SPEED TRIPLE	e11*92/61*00005	595RP		93	4.950	50 cm.
SPRINT ST	e11*92/61*00006	695AB		91	4.750	50 cm.
TIGER	e11*92/61*00007	709EN	TG700NK	87	4.100	50 cm.
			TG711NK, TG715NK			
TIGER	e11*92/61*00007	709EN	TG720WT	92	4.600	50 cm.
			TG730WT			
THUNDERBIRD	e11*92/61*00008	309RT		94	4.000	50 cm.
ADVENTURER "C"	e11*92/61*00009	309SN		93	4.000	50 cm.
THUNDERBIRD SPORT	e11*92/61*00010	309RD		93	4.250	50 cm.
LEGEND TT	e11*92/61*00011	309RL		92	4.000	50 cm.
SPRINT RS	e11*92/61*00014	695AC	TF605MH	91	4.750	50 cm.
			TF625MH			
SPRINT RS	e11*92/61*00014	695AC	F635MH	91	4.650	50 cm.
			TF615MH			
TT600	e11*92/61*00021	806AD	TH800/SX	96	6.375	50 cm.
			TH800/SY			
TT600	e11*92/61*00021	806AD	TH810/SX	95	6.350	50 cm.
			TH810/SY			
TT600	e11*92/61*00021	806AD	TH805/SX	94	6.300	50 cm.
			TH805/SY			
TT600	e11*92/61*00021	806AD	TH815/SX	95	6.350	50 cm.
			TH815/SY			
TT600	e11*92/61*00021	806AD	TH820/SX	92	4.650	50 cm.
			TH820/SY			
TT600	e11*92/61*00021	806AD	TH825/SX	92	4.650	50 cm.
			TH825/SY			
BONNEVILLE	e11*92/61*00030	908MD	TJ/900TM	91	3.650	50 cm.
			TJ/910TM			
BONNEVILLE	e11*92/61*00030	908MD	TJ/920TM	90	3.500	50 cm.
			TJ/925TM			
955 i	e11*92/61*00040	595SB	TE/520V1	94	5.350	50 cm.
			TE/521VR			
955 i	e11*92/61*00040	595SB	TE/530V1	94	5.300	50 cm.
			TE/531VR			
			TE/535V1			
			TE/536VR			

MARCA: **TRIUMPH**Motocicletas:

Denominación Comercial	Contraseña de Homologación	Tipo	Variante	NIVEL SONORO		
				dB (A)	r.p.m.	Distancia
955 i	e11*92/61*00040	595SB	TE/525V1	93	4.800	50 cm.
			TE/526VR			
955 i	e11*92/61*00040	595SB	TE/540V1	93	4.637	50 cm.
			TE/541VR			
			TE/545V1			
			TE/546VR			

MARCA: **YAMAHA**Ciclomotores:

Denominación Comercial	Contraseña de Homologación	Tipo	Variante	NIVEL SONORO		
				dB (A)	r.p.m.	Distancia
CY 50	CI-0064	3WG		84	5.250	7 m.
CY 50	CI-0064	3WG Ext. 1	I	84	5.250	7 m.
CY 50	CI-0064	3WG Ext. 2	II, III	84	5.250	7 m.
CY 50 R	CI-0064	3WG Ext. 3	IV, V	84	5.250	7 m.
CY 50 R	CI-0064	3WG Ext. 5	IX	84	5.250	7 m.
YA 50 F	CI-0064	3WG Ext. 4	VI, VII, VIII	84	5.250	7 m.
YA 50 R	CI-1003	4MJ		77	5.250	7 m.
CY 50 R	CI-1033	3WG	I, II	73	5.250	7 m.
YA 50 R						
CW 50 RS	CI-1034	4TD	I	69	4.875	7 m.
CW 50 RSP	CI-1034	4TD Ext. 1	II	69	4.875	7 m.
CW 50 RSX	CI-1034	4TD Ext.2	III	69	4.875	7 m.
TZR 50	CI-1070	4YV	I/ii	72	3.188	50 cm.
YN 50	CI-1076	5AD		78	3.100	50 cm.
DT 50 R	CI-1096	5BK		68	4.125	7 m.
YQ 50	CI-1097	5BR		73	5.250	7 m.
YH50	CI-1124	SA03		86	4.875	50 cm.
CW 50 R	CI-1146	SA05		87	4.950	50 cm.
EW 50	CI-1162	SA09		85	4.875	50 cm.
EW 50	e13*92/61*0017*00	SA09	I/i y iii	80	3.400	50 cm.
EW 50	e13*92/61*0017*03	SA09	I/v	79	3.375	50 cm.
CW 50 RS	e13*92/61*0029*00	SA05	1	81	3.400	50 cm.
YQ 50	e13*92/61*0036*00	SA14	I/i	77	3.375	50 cm.
YN 50 M	e9*92/61*0060*00	SA19		80	3.563	50 cm.



## MARCA: YAMAHA

## Motocicletas:

Denominación Comercial	Contraseña de Homologación	Tipo	Variante	NIVEL SONORO		
				dB (A)	r.p.m.	Distancia
SR 250	A-0078	3Y8 SR250 Ext. 2	21L (I)	89	3.850	7 m.
SR 250	A-0078	3Y8 SR250 Ext. 3	II, III IV, V	89	3.850	7 m.
SR 250	A-0078	3Y8 SR250 Ext. 4	VI VII, VIII	89	3.850	7 m.
SR 250	A-0078	3Y8 SR250 Ext. 5	IX	89	3.850	7 m.
XS 400	A-0109	12E, XS400	XS400	79	6.600	50 cm.
XS 400	A-0109	32G, XS400 Ext. 1	(S.O.)	79	6.600	50 cm.
XJ 750	A-0117	11M XJ750		82	6.750	7 m.
XJ 900	A-0118	31A XJ900		82	6.750	50 cm.
XJ 900	A-0118	31A XJ900 Ext. 1	Semicarenado	83'1	6.750	50 cm.
RD 350 LC	A-0160	31K RD350 LC		88'5	4.500	50 cm.
RD 350 LC	A-0160	31K RD350 LC Ext. 1	Mod. 85 Carenado	88'5	4.500	50 cm.
RD 350 LC	A-0160	1WT, RD350LC Ext. 2	1WT RD350	88'5	4.500	50 cm.
RD 350 LC	A-0160	31K, RD350LC Ext. 3	2UA Modelo Brasil	88'5	4.500	50 cm.
RD 350 LC	A-0160	31K RD350 LC Ext. 4	2UA (91)	88'5	4.500	50 cm.
CA 50	A-0161	14T, CA50		77	5.000	50 cm.
DT 75 / DT 80	A-0162	20L, DT75 DT 80 Ext. 1	2RY	88	8.000	7 m.
DT 80	A-0162	20L, DT75		88	8.000	7 m.
XJ 750	A-0174	41Y, XJ750		83'8	6.750	50 cm.
XJ 600	A-0177	51J, XJ600		82'6	7.500	7 m.
XJ 600	A-0177	51J, XJ600 (1)	XJ600 (Mod. 89)	82'6	7.500	7 m.
FJ 1100	A-0182	36Y, FJ1100		89'5	6.750	7 m.
XT 600	A-0183	43F, XT600		77'7	4.875	7 m.
FZ 750	A-0208	1FN, FZ750		86'2	7.875	50 cm.
FZ 750	A-0208	1FN, FZ750 Ext. 1	2MG	86'2	7.875	50 cm.
FZ 750	A-0208	1FN, FZ750 Ext.2	2MG '87	86'2	7.875	50 cm.
XJ 900 F	A-0209	58L, XJ900F		83'1	6.750	50 cm.
RD 75 LC	A-0211	1NM, RD75LC		68	6.750	7 m.
FJ 1200	A-0229	1TX, FJ1200		85'4	6.750	50 cm.
SRX 600	A-0232	1XL, SRX600		78'2	4.875	7 m.
RD 125 LC	A-0244	1GX, RD 125 LC		82	4.750	50 cm.



## MARCA: YAMAHA

## Motocicletas:

Denominación Comercial	Contraseña de Homologación	Tipo	Variante	NIVEL SONORO		
				dB (A)	r.p.m.	Distancia
RD 125 LC	A-0244	1GX, RD125 LC Ext.1	Mod. '87	82	4.750	50 cm.
SR 125	A-0253	2JW, SR125		83	6.375	50 cm.
XT 350	A-0274	55V, XT350		86	3.750	50 cm.
FZR 1000	A-0275	2GH, FZR 1000		91	5.000	50 cm.
DT 80 LC	A-0276	53W DT80 LC		72'6	6.750	7 m.
DT 80 LC	A-0276	53W, DT80 LC Ext. 1	Neumáticos, freno	72'6	6.750	7 m.
DT 125 LC	A-0280	BL DT,125 LC		72'5	6.750	7 m.
XT 600	A-0284	2KF, XT600		89	3.250	50 cm.
TZR 125	A-0285	2RN, TZR125		77'8	7.875	50 cm.
TZR 125	A-0285	2RN, TZR125 Ext. 1	3PE TZR125	77'8	7.875	50 cm.
TZR 80	A-0286	2UV, TZR80		68'3	7.125	50 cm.
TZR 80	A-0286	2UV, TZR80 Ext.1	3YG TZR80	68'3	7.125	50 cm.
XT 600 Z	A-0287	1VJ, XT600Z		86'3	3.250	50 cm.
XT 600 Z	A-0296	3AJ, XT600Z		82	3.250	50 cm.
XT 600 Z	A-0296	3AJ, XT600Z Ext. 1	Mod. '89	82	3.250	50 cm.
FJ 1200	A-0297	3CV, FJ1200		98	6.375	50 cm.
FJ 1200	A-0297	3CV, FJ1200 Ext.1	Mod. '90	98	6.375	50 cm.
LB 8011 '88	A-0330	3JG, LB8011		87	4.875	50 cm.
FZR 600	A-0347	3HE, FZR600		93	5.250	50 cm.
FZR 600	A-0347	3HE, FRZ600 Ext. 1	Mod. '89	93	5.250	50 cm.
FZR 600	A-0347	3HE, FRZ600 Ext. 2	Mod. '90	93	5.250	50 cm.
FZR 1000	A-0348	3GM, FZR 1000		97	7.500	50 cm.
FZR 1000	A-0348	3GM FZR 1000 Ext. 1	Mod. '90	97	7.500	50 cm.
FZR 1000	A-0348	3GM FZR 1000 Ext. 2	Mod. '91	97	7.500	50 cm.
VIRAGO 535	A-0349	2YL, XV535		91	3.750	50 cm.
VIRAGO 535	A-0349	2YL, XV535 Ext. 1	Mod. '95	91	3.750	50 cm.
VIRAGO 535	A-0349	2YL, XV535 Ext. 2	Mod. '96	91	3.750	50 cm.



## MARCA: YAMAHA

## Motocicletas:

Denominación Comercial	Contraseña de Homologación	Tipo	Variante	NIVEL SONORO		
				dB (A)	r.p.m.	Distancia
SUPER TENERE 750	A-0357	3SC, XTZ750		95	5.625	50 cm.
XT 600 E	A-0392	3TB, XT600E		84	3.250	50 cm.
XT 600 E	A-0392	3TB, XT600E	(II)	84	3.250	50 cm.
		Ext. 1				
XT 600 E	A-0392	3TB, XT600E	(III)	84	3.250	50 cm.
		Ext. 2				
CH 80	A-0396	3WU, CH80	CH80	85	4.000	50 cm.
XT 350	A-0426	3YT, XT350		84	3.500	50 cm.
VIRAGO 1100	A-0429	3LP, XV1100		88	3.000	50 cm.
VIRAGO 1100	A-0429	3LP, XV1100	Mod. '94	88	3.000	50 cm.
		Ext. 1				
VIRAGO 1100	A-0429	3LP, XV1100	Mod. '95	88	3.000	50 cm.
		Ext. 2				
FZ 750	A-0431	3KS, FZ750		94	5.125	50 cm.
XJ 600	A-0432	3KM, XJ600		93	5.000	50 cm.
FJ 1200	A-0433	3XW, FJ1200		92	4.250	50 cm.
XTZ 660	A-0436	3YF, XTZ660		82	3.125	50 cm.
TENERE 660	A-0436	3YF, XTZ660	Mod. '94	82	3.125	50 cm.
		Ext. 1				
XTZ 600	A-0436	3YF, XT600 Ext.2	Mod. '95	82	3.125	50 cm.
TDM 850	A-0437	3VD, TDM 850		90	3.750	50 cm.
JOG 90	A-0447	4CX, CY90		82	3.500	50 cm.
XJ 600 S	A-0460	4BR	XJ600S	89	4.250	50 cm.
XJ 600 S	A-0460	4BR, Ext. 1	XJ600S (II)	89	4.250	50 cm.
XJ 600 N	A-0460	4BR, Ext. 2	XJ600S (III)	89	4.250	50 cm.
XJ 600 S/N	A-0460	4BR, Ext. 3	XJ600S/N	89	4.250	50 cm.
		(IV, V)				
TZR 80 RR	A-0486	4BA, TZR80RR		76	4.375	50 cm.
TZR 80	A-0486	4BA, Ext. 1	Sin carenado	76	4.375	50 cm.
V-MAX 12'88	A-0487	2EN, VMX12		89	4.000	50 cm.
VIRAGO 750	A-0488	4FY		90	3.500	50 cm.
VIRAGO 750	A-0488	4FY, Ext. 1	4FY '94	90	3.500	50 cm.
VIRAGO 250	A-0489	3LS, XV250		88	4.000	50 cm.
VIRAGO 250	A-0489	3LS, VX250 Ext. 1	(I) '94	88	4.000	50 cm.
FLY ONE	A-0490	3UH, XC150		91	3.500	50 cm.
CW 65	A-0506	4GP		82	3.500	50 cm.
GTS 1000	A-0510	4BH		90	4.500	50 cm.
YZF 750 R	A-0525	4HD		93	6.000	50 cm.
YZF 750 R	A-0525	4HD, Ext. 1	4HD '95	93	6.000	50 cm.



## MARCA: YAMAHA

## Motocicletas:

Denominación Comercial	Contraseña de Homologación	Tipo	Variante	NIVEL SONORO		
				dB (A)	r.p.m.	Distancia
YZF 750 SP	A-0526	4HS YZF750SP		92	6.000	50 cm.
DT 80 LC	A-0542	3JXS, DT80LC		75	3.875	50 cm.
TT 600	A-0543	4LW		86	3.250	50 cm.
TT 600 E	A-0543	4LW, Ext. 1	4LW	86	3.250	50 cm.
		TT600E '96				
FZR 600 R	A-0562	4HJ, FZR600R		93	5.750	50 cm.
FZR 600 R	A-0562	4HJ, Ext. 1	(I) '95	93	5.750	50 cm.
VIRAGO 750	A-1000	4PW, XV750		90	3.500	50 cm.
DIVERSION 900	A-1001	4KM, XJ900S		88	4.125	50 cm.
XC 125 T	A-1002	4NB, XC125T		82	3.750	50 cm.
CYGNUS	A-1002	4NB, Ext.1	XC125TR '96	82	3.750	50 cm.
YE 80	A-1003	4JC, YE80		82	3.750	50 cm.
XJR 1200	A-1012	4PU, XJR1200		90	4.000	50 cm.
YP 250	A-1038	4UC		87	3.750	50 cm.
TRX 850	A-1039	4UN		87	3.750	50 cm.
SRZ 660	A-1040	4SU		88	3.250	50 cm.
YZF 1000 R	A-1048	4SV		92	5.000	50 cm.
YZF 600 R	A-1049	4TV		90	5.750	50 cm.
YZF 600 R	A-1049	4TV, Ext. 1	II Y II (25KW)	90	5.750	50 cm.
TDM 850	A-1053	4TX		87	3.750	50 cm.
XVZ 1300 A	A-1056	4NK		89	3.562	50 cm.
XVZ 1300 A	A-1076	4YP		92	3.750	50 cm.
XVS 650	A-1077	4VR	4XR	86	3.250	50 cm.
XV 125	A-1078	5AJ		84	4.000	50 cm.
XJ 600 S	A-1104	RJ01	25 kW-44'8 kW	88	4.250	50 cm.
YZR-R1	A-1121	RN01		90	5.000	50 cm.
SR 125	A-1122	10F		82	4.250	50 cm.
TT 600 R	A-1123	DJ01		92	3.250	50 cm.
FORCE 1	A-1127	4NS		88	3.750	50 cm.
YP 250 D	A-1128	SG02		84	3.250	50 cm.
FZS 660	A-1129	RJ02	Full Power	91	5.750	50 cm.
FZS 660	A-1129	RJ02	25 kW	86	4.750	50 cm.
XVS 650 A	A-1130	VM02		83	3.200	50 cm.
XV 535	A-1144	VJ01		91	3.500	50 cm.
YP 125	A-1145	SE02		89	4.375	50 cm.
TW 125	A-1163	DE01		81	4.500	50 cm.
XV 250	A-1164	VG01		88	4.000	50 cm.
WR 400	A-1165	CH02		94	4.125	50 cm.
WR 400	A-1165	CH02	CH04	94	4.125	50 cm.



**MARCA: YAMAHA**

**Motocicletas:**

Denominación Comercial	Contraseña de Homologación	Tipo	Variante	NIVEL SONORO		
				dB (A)	r.p.m.	Distancia
XJR 1300	A-1181	RP02		83	3.125	50 cm.
XT 600 E	A-1182	DJ02		83	3.125	50 cm.
DT 125 R	A-1186	DE03		77	3.500	50 cm.
XVS 1100	A-1187	VP05		85	2.875	50 cm.
YZF-R6	A-1188	RJ03		93	6.500	50 cm.
WR 250 F	e1*92/61*00106	CG		88	4.750	50 cm.
WR 400 F	e1*92/61*00107	CJ		91	4.250	50 cm.
YP 125	e9*92/61*0046	SE06	I/i y iii	89	4.375	50 cm.
YP 150	e9*92/61*0047	SG08	I/i y iii	81	4.125	50 cm.

